



1.0 GENERAL DESCRIPTION

- 1.1 The assembly is an electrical panel board designed for industrial use with battery chargers, utility-sized batteries, and *dc load* distribution. The panel features multiple dc branch breakers, and one (1) or more 2-pole main circuit breaker(s).
- 1.2 The DC Control Panel model (ordering numbers) feature a smart part code, common examples are:
 - 1.2.1 **DCP38100...** Style-MH38 enclosure, maximum of (12) branch breakers, 100A main breaker
 - 1.2.2 **DCP38200...** Style-MH38 enclosure, maximum of (12) branch breakers, 200A main breaker
 - 1.2.3 **DCP38LUG...** Style-MH38 enclosure, maximum of (12) branch breakers, direct main lugs
 - 1.2.4 **DCP56100...** Style-MH56 enclosure, maximum of (24) branch breakers, 100A main breaker
 - 1.2.5 **DCP56200...** Style-MH56 enclosure, maximum of (24) branch breakers, 200A main breaker
 - 1.2.6 **DCP56LUG...** Style-MH56 enclosure, maximum of (24) branch breakers, direct main lugs



- 1.3 The DC Control Panel is a National Recognized Testing Laboratory (NRTL) listed, and labeled product. It is certified to standards **UL 508A & CSA C22.2 No. 14-23**. All DCP models are **CSA**-labeled via Special Industrial Control Panel (SICP) Shop Program.
- 1.4 The DC Control Panel utilizes "*branch*" dc distribution circuit breakers, which meet and are listed to **UL 489**.
- 1.5 Site Installation Configurations:
 - 1.5.1 The main circuit breaker can serve as a disconnect for dc load branching.
 - 1.5.2 The main circuit breaker can be used as a battery disconnect, when one (1) of the branch breakers is specially wired (and marked) as a charger input.
 - 1.5.3 The panel can be supplied *without* a main breaker, replaced with direct dc bus connection lugs.
- 1.6 For further DC Control Panel product details, refer to manufacturer's standard specification ([JF5033-20](#)).

2.0 CONFIGURATION / APPLICATION

2.1 Main / Load Circuit Breakers

This configuration provides a main load circuit breaker to isolate the dc loads from the charger *and* battery. It is used to shed all loads from the common dc bus for service.

This configuration closely mimics standard panel boards, with main and load breakers mounted together.

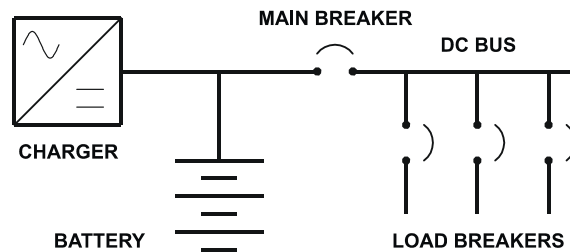

2.2 Battery Disconnect Circuit Breaker

This configuration provides a battery circuit breaker to isolate the charger *and* dc loads from the battery. It allows the charger to continue to provide power to the dc loads during service to the battery.

One (1) of the branch circuit breakers is configured as a "back-feed".

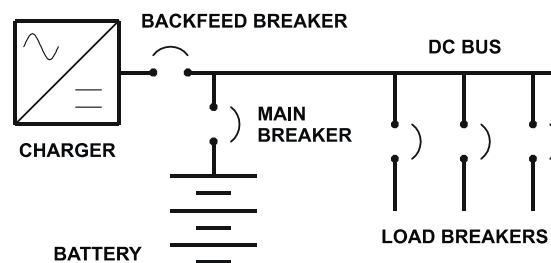

2.3 Load Circuit Breakers

This configuration, with *no* main breaker, connects the loads to the dc bus without a local disconnect. The battery is wired directly to the charger, or has an external battery disconnect.

Battery disconnects in these instances are typically located near the battery.

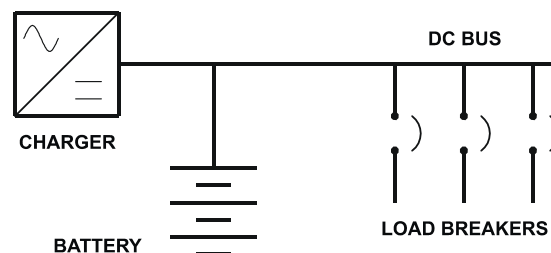

3.0 MECHANICAL ASSEMBLY / INSTALLATION

3.1 The DC Control Panel is housed a Style-MH38 or Style-MH56 NEMA Type-1 enclosure, constructed with 16 GA sheet steel. Finish is ANSI-61 gray epoxy powder-coat paint.

Enclosure Overall Dimensions:

38.00in	(965mm)	H	(MH38 - 1-12 bkrs)
56.00in	(1422mm)	H	(MH56 - 13-24 bkrs)
20.12in	(511mm)	W	
5.90in	(150mm)	D	

Outline Drawing:

<http://www.ATSeries.net/PDFs/JE5368-00.pdf>

3.2 The DC Control Panel is to be surface-mounted, using the four (4) rear mounting holes.

Rear Mounting Dimensions:

32.00in	(813mm)	H	(MH38 - 1-12 bkrs)
50.00in	(1270mm)	H	(MH56 - 13-24 bkrs)
15.00in	(381mm)	W	

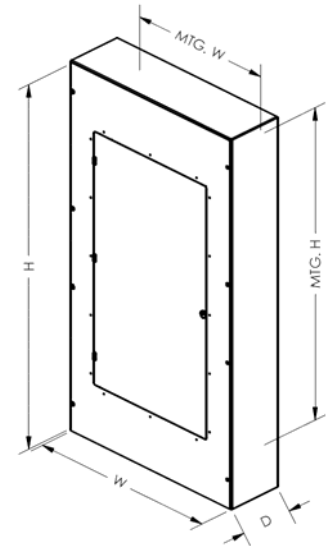

3.3 If the DC Control Panel is to be rack-mounted, optional 23/24in (584/610mm) brackets (p/n [EI0193-23](#)) can be supplied from the factory, or field-installed from a kit.

3.4 The Style-MH38 and Style-MH56 enclosures feature multiple pre-fab conduit knockouts on the **top** panel of the chassis as standard. Optional bottom or dual knockouts are also available. See outline drawing ([JE5368-00](#)) for details. If additional conduit knockouts are required, enclosure should be field-modified by installer.

3.5 The DC Panel installation weight varies, depending on enclosure, type of main, and number of branch breakers.

3.5.1 MH38 (1-12 bkrs) starting at: 120 lb / 54.4 kg / 3.5.2 MH56 (13-24 bkrs) starting at: 175 lb / 79.4 kg

4.0 EXTERNAL WIRING - ⚠ WARNING

4.1 **Shut down and lock-out all external power** to the DC Control Panel before making charger, battery & dc load user connections.

4.2 Refer to the supplied standard drawing ([JE5368-00](#)) for component identification and internal specifications.



4.3 For user grounding to chassis, the DCP features one (1) CU-AL compression lug, accepting #14 - 1/0 AWG wire. The ground lug is located in the lower-left corner of assembly, and clearly labeled.

4.3.1 An **optional** ground bus bar (p/n EI0195-50) is also available.

4.4 User-supplied wiring from the DC Control Panel to the battery and/or dc loads should be utilized per NEC, local, and site codes. Size dc wiring per equipment specifications and **proper bend radius**. **NOTICE** Use copper (CU) wiring **only**. The main and load circuit breakers feature compression screw terminals for user-installed I/O connections.

4.4.1 100A (H-frame) main breaker will accept #14 - 3/0 AWG wire

4.4.2 200A (J-frame) main breaker will accept 3/0 - 300 MCM wire

4.4.3 CU-AL lugs (no main) will accept #6 AWG - 350 MCM wire

4.4.4 15-125A (B-frame) branch bkrs will accept #14 - 3/0 AWG wire

4.5 For correct dc polarity, follow the **POS(+)** and **NEG(-)** labeling on the center bus bars, to user connections on the main and branch circuit breakers.

4.6 Check and confirm polarity (+/-), of **all** dc cabling connections from the battery and loads.

4.7 Re-install front panel door, then turn **on** (close) main feeder breaker.

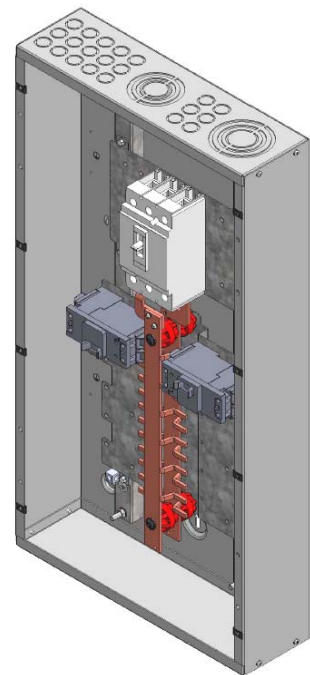

5.0 EXPANSION

5.1 For branch dc distribution breaker future expansion, refer to Service Instruction ([JD5070-05](#)).