

NOTES:

- 1) ENCLOSURE IS A NEMA TYPE 1 / IP20 TOP-VENTED STEEL CABINET WITHOUT GASKETS. FINISH IS ANSI-61 GRAY EPOXY POWDERCOAT.
- 2) ALLOW 6in / 152mm OF FREE AIR ON ALL VENTED SURFACES FOR COOLING.
- 3) FOUR (4) KEY-HOLE SLOTS ARE PROVIDED ON BACK OF ENCLOSURE AS SHOWN, FOR WALL-MOUNTING WITH 0.25in / 6.25mm HARDWARE.
- 4) FOUR (4) 1.31in / 33mm DIA KNOCKOUTS ARE PROVIDED AS SHOWN, WITH TWO (2) ADDITIONAL KNOCKOUTS FEATURED ON BOTTOM PANEL OF ENCLOSURE. USE OF ANY OF THESE FOUR (4) LOWER CONDUIT KNOCKOUTS WILL ALLOW REMOVAL OF CABINET SHROUD WITHOUT REMOVAL OF EXTERNAL WIRING.
- 5) DATA NAMEPLATE DECAL (WITH CHARGER RATINGS) APPLIED TO LEFT SIDE OF ENCLOSURE.
- 6) BATTERY CHARGER SHIPPING WEIGHT: SEE PRODUCT LITERATURE
- 7) OPTIONAL PENTHOUSE ENCLOSURE SUPPLIED TO HOUSE AUXILIARY ALARM RELAY PC BOARD (A5) AND MED/HIGH CIRCUIT BREAKERS.

DUAL DIMENSIONS in mm

6-25ADC W/ COMMON OPTIONS

			THIRD ANGLE PROJECTION				1075 Saint John Street Easton, PA 18042-6661 PH 610-330-9000 FAX 610-330-8510 www.hindlepowerinc.com	
			DRAWN BY <b>KMW</b> 110121		TITLE <b>AT10.1 SERIES BATTERY CHARGER OUTLINE: NEMA-1 STYLE-586 ENCLOSURE W/PENTHOUSE</b>			
			ELECTRONIC APPROVAL SIGNATURES MAINTAINED BY MFG ECN LOG		DRAWING No <b>JE5023-21</b>		REV <b>0</b> <b>B</b>	
<b>0</b>	<b>N/A</b>	<b>110121</b>	UNLESS OTHERWISE NOTED DIMENSIONS ARE IN INCHES. TOLERANCES ARE:		SCALE <b>NTS</b>		SHEET <b>1</b> OF <b>1</b>	
REV	ECN No	DATE			SALES No			

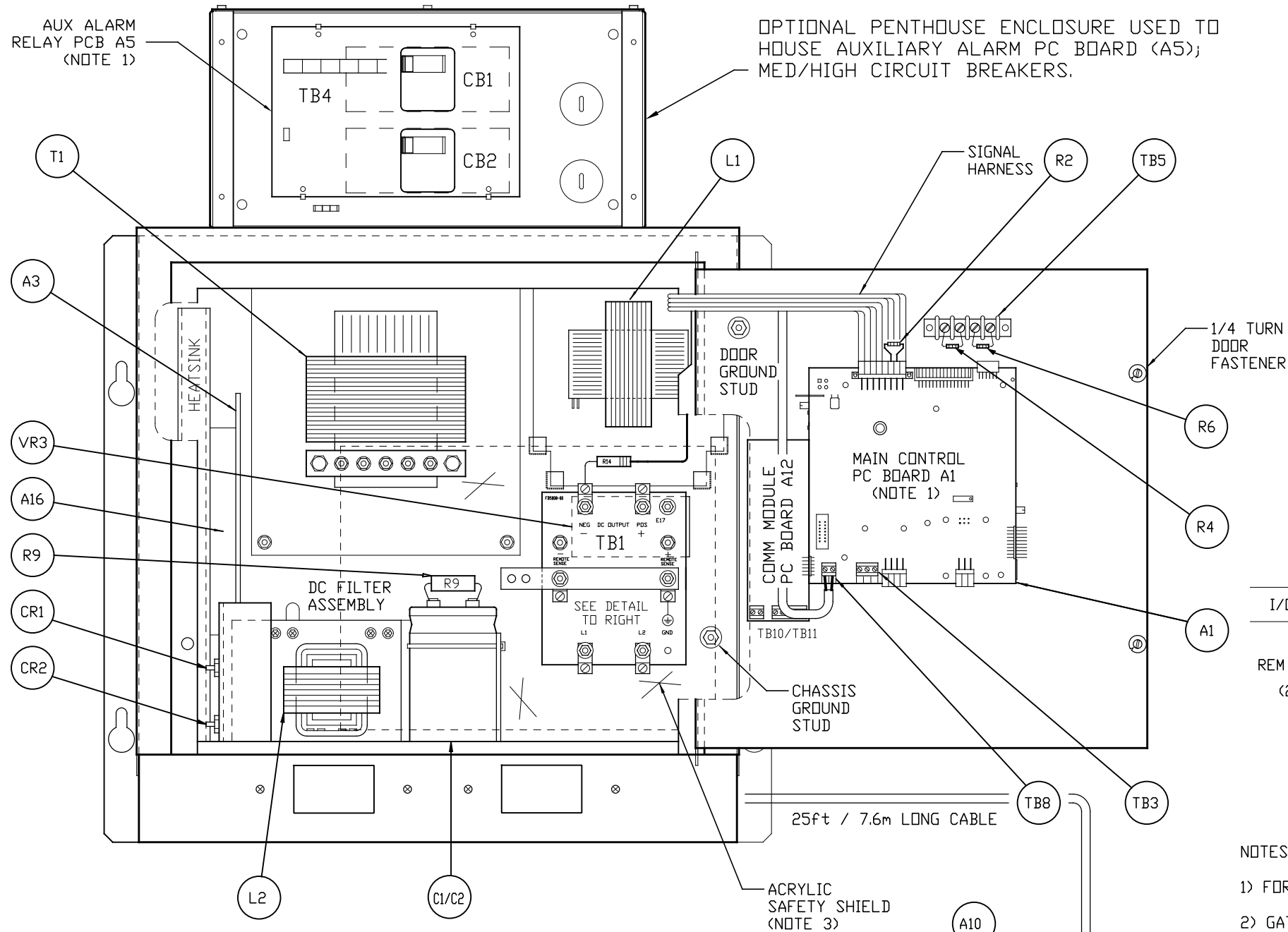

STYLE-586/594  
INPUT-OUTPUT  
TERMINAL BOARD  
TB1 DETAIL

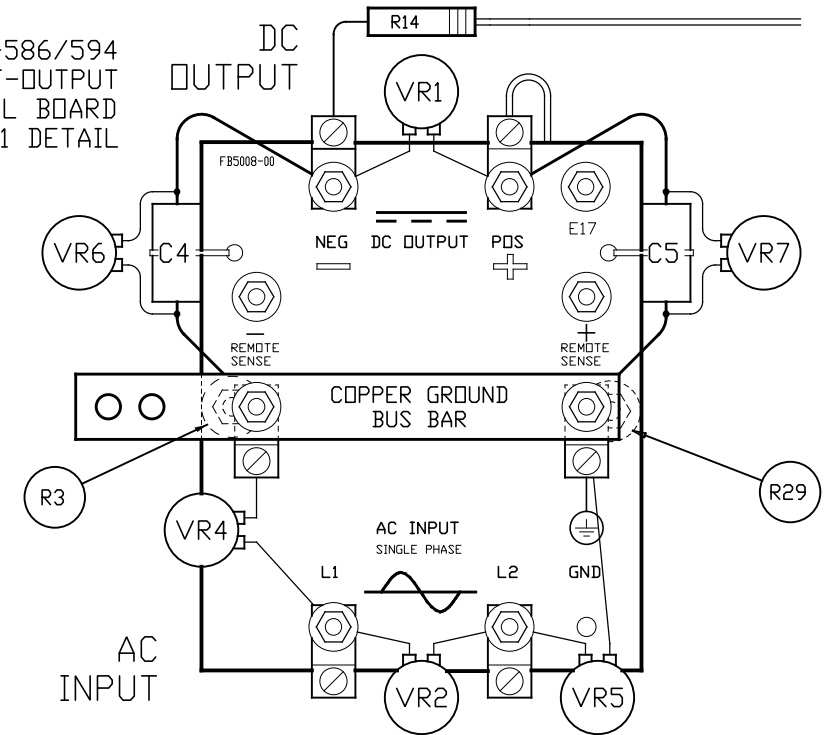

I/O TERMINAL	DESCRIPTION - TYPE	CONNECTION
TB1(+/-)	POS/NEG OUTPUT TERMINALS - CU-ALUMINUM COMPRESSION LUG	#14-6 AWG
REM SENSE(+/-)	POS/NEG REMOTE SENSE TERMINALS - 10-32 ZPS STUDS	#10 RING LUG
(2) TB1-GND	USER GROUND TERMINAL - CU-ALUMINUM COMPRESSION LUG	#14-6 AWG
TB1-L1/L2	AC INPUT TERMINALS - CU-ALUMINUM COMPRESSION LUG	#14-6 AWG
TB3	SUMMARY ALARM TERMINAL BLOCK - SOLDERLESS COMP SCREW	#22-14 AWG
TB4	AUXILIARY ALARM TERM BLOCK - SOLDERLESS COMP SCREW	#22-14 AWG
TB8	TEMPCD PROBE (A10) TERM BLK - SOLDERLESS COMP SCREW	#22-14 AWG

NOTES:

- FOR DETAIL VIEWS OF ALL PC BOARDS (A1, A5, etc.) SEE DRAWING JE5030-21.
- GATE DRIVER PC BOARD (A3) AND RECTIFIER SCR MODULE (A16) ARE CONTAINED WITHIN ONE ASSEMBLY EJ5085-00 (LISTED AS "A6" IN PARTS DATA PACKAGE REPORT).
- SAFETY COVER DISPLAYS COMPONENT LAYOUT DIAGRAM, SCHEMATIC & INSTALLATION NOTES.

AT10.1 GROUP I STANDARD COMPONENTS

SYMBOL	DESCRIPTION
A1	MAIN CONTROL PRINTED CIRCUIT BOARD
A3	RECTIFIER GATE DRIVER PC BOARD
A16	RECTIFIER SCR MODULE (NOTE 2)
C4/C5	DC OUTPUT EMI FILTER CAPACITOR (-/+)
CB1	AC INPUT CIRCUIT BREAKER (STANDARD)
CB2	DC OUTPUT CIRCUIT BREAKER (STANDARD)
L1	MAIN INDUCTOR
R2	CURRENT RATING RESISTOR
R3	PWR SUPPLY BALLAST RESISTOR (48VDC)
R4	SCALING RESISTOR (POSITIVE LEG)
R6	VOLTAGE CROWBAR RESISTOR
R14	SCALING RESISTOR (NEGATIVE LEG)
T1	POWER ISOLATION TRANSFORMER
TB3	SUMMARY ALARM CONTACTS
TB5	RESISTOR (R4/R6) TERMINAL BLOCK
TB8	TEMPCD PROBE (A10) TERMINAL BLOCK
VR1	DC OUTPUT SURGE SUPPRESSOR (- TO +)
VR2	AC INPUT SURGE SUPPRESSOR (L1 TO L2)

SYMBOL	DESCRIPTION
VR4/VR5	AC INPUT SURGE SUPPRESSOR (L1/L2)
VR6/VR7	DC OUTPUT SURGE SUPPRESSOR (-/+)

FEATURED AT10.1 GROUP I OPTION COMPONENTS	
A5	AUXILIARY ALARM RELAY PC BOARD
A10	EXTERNAL TEMPERATURE COMPENSATION PROBE
C1	FILTER CAPACITOR
C2	BATTERY ELIMINATOR FILTER CAPACITOR
CR1	POLARITY DIODE
CR2	BLOCKING DIODE
L2	FILTER INDUCTOR
R9	FILTER CAPACITOR (C1) BLEED RESISTOR
TB4	AUX RELAY PCB (A5) ALARM TERMINAL BLOCK
R29	COMMUNICATIONS MODULE POWER SUPPLY RESISTOR
VR3	AC LIGHTNING ARRESTOR (LOCATED BEHIND I/O)
A12	COMMUNICATIONS MODULE PC BOARD

6-25ADC W/ COMMON OPTIONS

			 THIRD ANGLE PROJECTION		 1075 Saint John Street Easton, PA 18042-6661 PH 610-330-9000 FAX 610-330-8510 www.hindlepowerinc.com	
			DRAWN BY <b>KMW</b>	<b>110121</b>	TITLE <b>AT10.1 SERIES BATTERY CHARGER INTERNAL COMPONENT LAYOUT: STYLE-586/594</b>	
			ELECTRONIC APPROVAL SIGNATURES MAINTAINED BY MFG ECN LOG		DRAWING No <b>JE5027-21</b>	REV <b>0</b>
<b>0</b>	N/A	<b>110121</b>	UNLESS OTHERWISE NOTED DIMENSIONS ARE IN INCHES. TOLERANCES ARE:		SCALE <b>NTS</b>	SHEET <b>1</b> OF <b>1</b>
REV	ECN No	DATE	SALES No		FILENAME [JH0014-21.DWG]	

INDICATOR LIGHTS (LEDs):

- |                                     |                                  |
|-------------------------------------|----------------------------------|
| DS01 - GREEN - AC ON                | DS10 - RED - LOW LEVEL DETECT    |
| DS02 - RED - DC VOLTS               | DS11 - RED - (METER DISPLAY)     |
| DS03 - RED - DC AMPERES             | DS12 - RED - (METER DISPLAY)     |
| DS04 - RED - EQUALIZE HRS REMAINING | DS13 - RED - HIGH DC VOLTAGE     |
| DS05 - GREEN - FLDAT                | DS14 - RED - LOW DC VOLTAGE      |
| DS06 - AMBER - EQUALIZE             | DS15 - RED - DC OUTPUT FAILURE   |
| DS07 - AMBER - MANUAL TIMER         | DS16 - RED - AC INPUT FAILURE    |
| DS08 - AMBER - MANUAL EQUALIZE      | DS17 - RED - POS(+) GROUND FAULT |
| DS09 - AMBER - AUTO EQUALIZE TIMER  | DS18 - RED - NEG(-) GROUND FAULT |

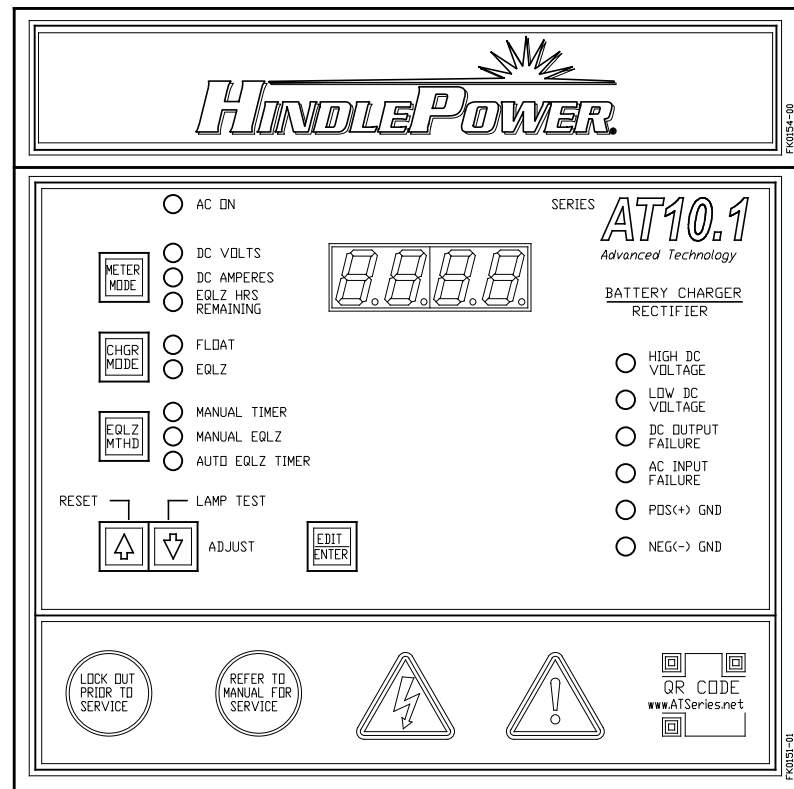

CONTROL PANEL  
(PART No. FK0151-01)

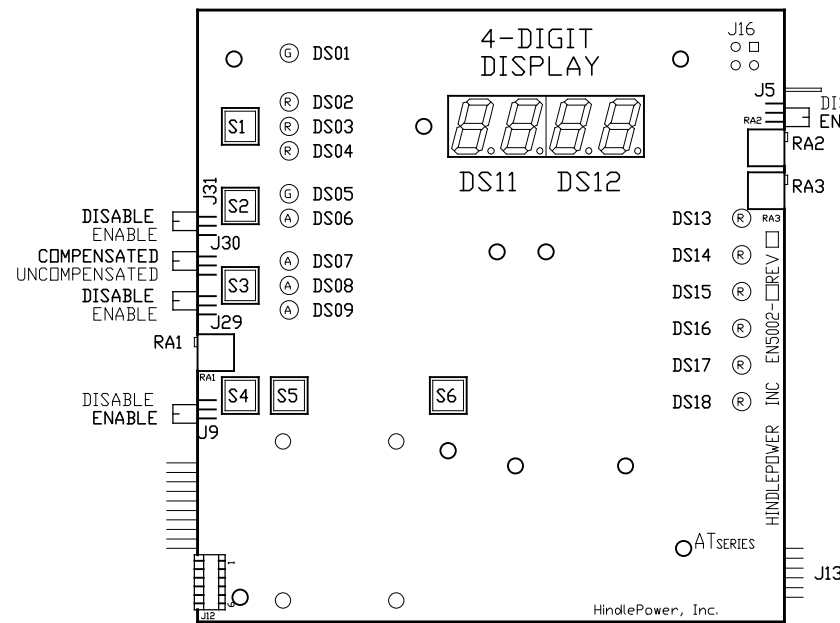

MAIN CONTROL PC BOARD (A1)

FRONT VIEW - FACING CHARGER DOOR WHEN INSTALLED

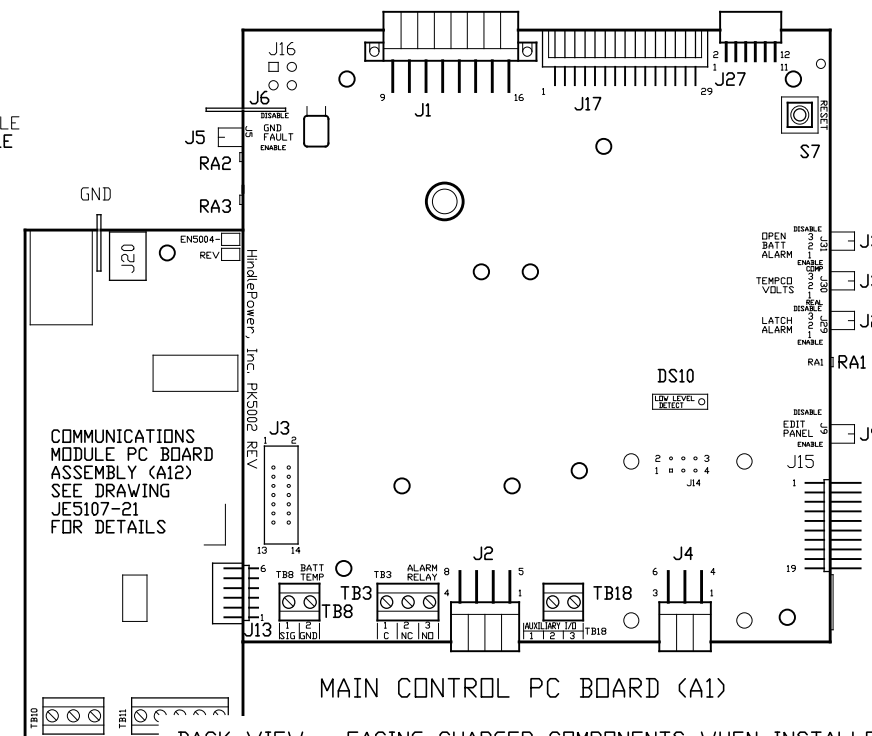

MAIN CONTROL PC BOARD (A1)

BACK VIEW - FACING CHARGER COMPONENTS WHEN INSTALLED

NOTE: UNLESS OTHERWISE SPECIFIED, ALL ALARM TERMINAL BLOCKS (TB3/TB4/TB8) ARE SOLDERLESS COMPRESSION TERMINALS, ACCEPTING #22-14 AWG WIRE. ALL ALARM CONTACTS SHOW IN NON-ALARM STATE, WITH CHARGER ENERGIZED AND ALARM RELAYS ENERGIZED (FAIL SAFE). ALL ALARM CONTACTS WILL CHANGE STATE WHEN CHARGER IS POWERED DOWN. CONTACT RATING IS 0.5A @ 125VAC/VDC RESISTIVE.

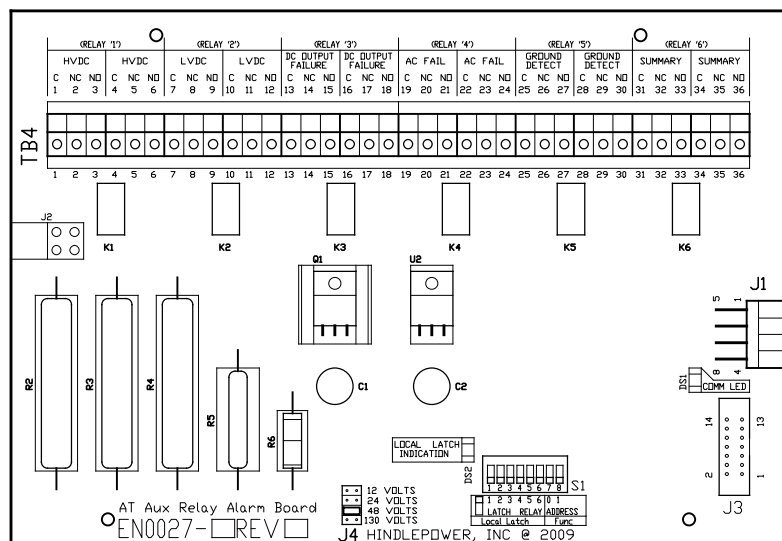

AUXILIARY ALARM RELAY PC BOARD (A5)

A5-J1 CONNECTED TO  
A1-J2 VIA EH5045-0#  
8-PIN SERIAL CABLE

OTHER CONTROLS:  
RA1 - LOW LEVEL  
DETECT ADJUST  
RA2 - GROUND FAULT  
BALANCE  
RA3 - GROUND FAULT  
SENSITIVITY

NON-USER ACCESSED JUMPERS:  
J3 - OLD A5 RIBBON CONNECTOR  
J12 - BOARD PROGRAMMING  
J14 - OLD FORCED LOAD SHARING  
J15 - MANUFACTURING TEST  
J16 - OLD INTERNAL TEMP

USER JUMPERS:

- J1 - MAINFRAME SIGNAL HARNESS (NOT USED IN 30-100A)
- J2 - AUX ALARM RELAY BOARD (A5) SERIAL CONNECTOR
- J4 - FORCED LOAD SHARING CABLE INTERCONNECTOR
- J5 - GROUND FAULT ENABLE/DISABLE
- J6 - EARTH GROUND CONNECTOR
- J9 - FRONT PANEL ENABLE/DISABLE (LOCKOUT)
- J13 - COMMUNICATIONS PC BOARD (A12) INTERCONNECTOR
- J17 - HO GATE DRIVER PC BOARD (A11) INTERCONNECTOR

- J27 - not used (3PH GATE DRIVER INTERCONNECTOR)
- J29 - LATCHING ALARMS ENABLE/DISABLE SELECTOR
- J30 - TEMPCO VOLTAGES (COMPENSATED/UNCOMP) SELECTOR
- J31 - BATTERY OPEN ALARM ENABLE/DISABLE SELECTOR

SWITCHES:

- S1 - METER MODE
- S2 - CHARGER MODE
- S3 - EQUALIZE METHOD
- S4 -  $\Delta$  ADJUST
- S5 -  $\nabla$  ADJUST
- S6 - EDIT / ENTER
- S7 - PROCESSOR MANUAL RESET

TERMINAL BLOCKS:

- TB3 - SUMMARY ALARM RELAY CONTACTS
- TB4 - AUX ALARM RELAY CONTACTS
- TB8 - DPT TEMPCO PROBE (A10) CONN
- TB18 - REM SHUTDOWN INTERFACE

6-25ADC W/ COMMON OPTIONS

			THIRD ANGLE PROJECTION		<b>HINDLEPOWER</b>		1075 Saint John Street Easton, PA 18042-6661 PH 610-330-9000 FAX 610-330-8510 www.hindlepowerinc.com	
			DRAWN BY <b>KMW</b> 110121		TITLE <b>AT10.1 SERIES BATTERY CHARGER CONTROL PANEL / PC BOARD DETAIL</b>			
			ELECTRONIC APPROVAL SIGNATURES MAINTAINED BY MFG ECN LOG		DRAWING No <b>JE5030-21</b>		REV <b>0</b> <b>B</b>	
0 N/A 110121			UNLESS OTHERWISE NOTED DIMENSIONS ARE IN INCHES. TOLERANCES ARE:		SCALE <b>NTS</b>		SALES No	
REV	ECN No	DATE			SHEET <b>1</b> OF <b>1</b>			

T1 CONNECTION TABLE	
INPUT	JUMPER
120	H1-H3, H2-H5
208	H2-H4 (2)
240	H2-H3 (2)

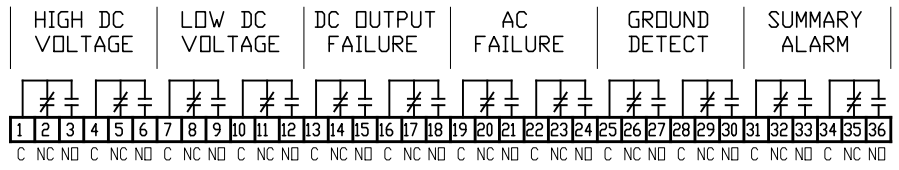
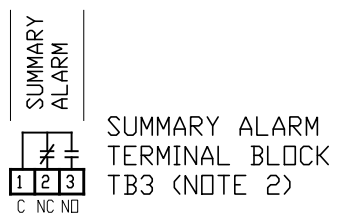
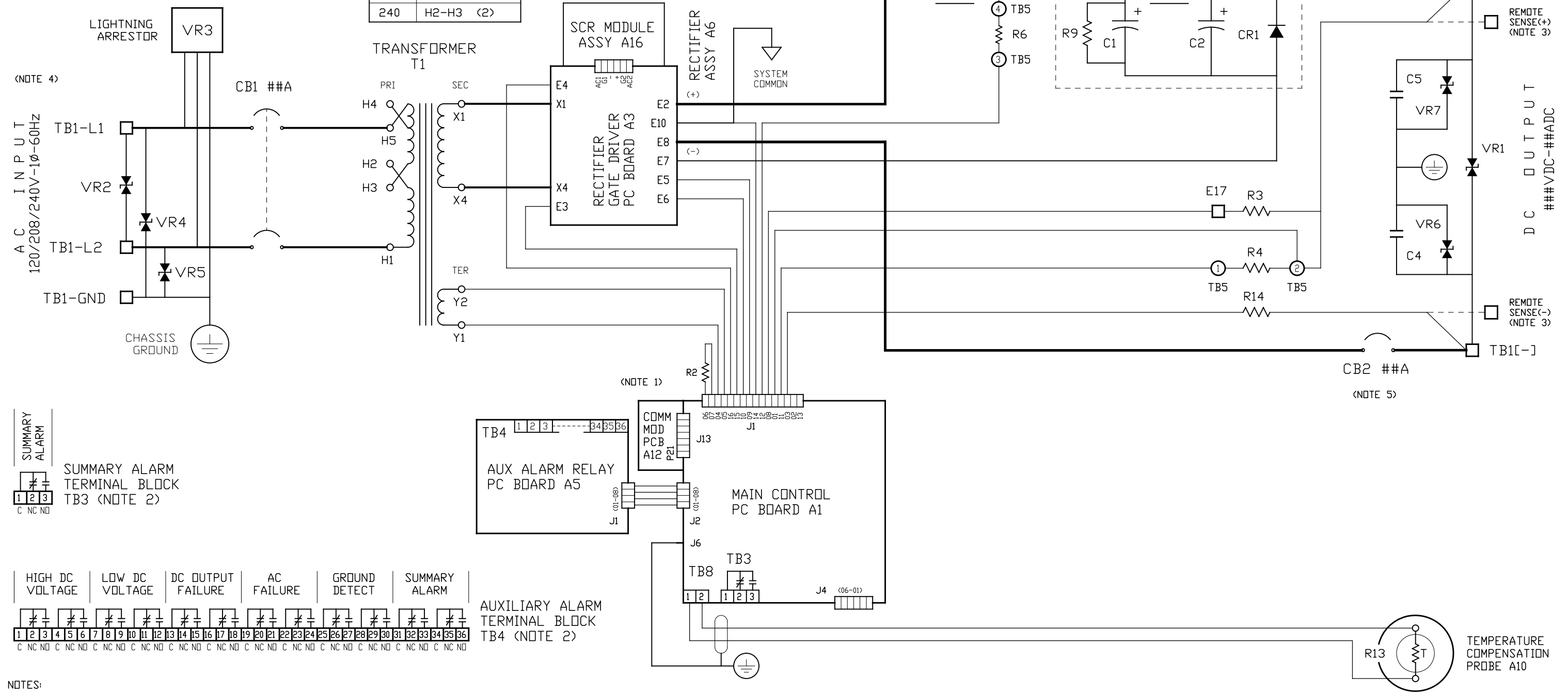

- NOTES:
- FOR COMPONENT DETAILS OF ALL PC BOARDS (A1, A5, A11, etc.) SEE DETAIL DRAWING JE5030-21.
  - ALL ALARM CONTACTS SHOWN IN NON-ALARM STATE, WITH CHARGER ENERGIZED AND ALARM RELAYS ENERGIZED (FAIL SAFE). ALL ALARM CONTACTS WILL CHANGE STATE WHEN CHARGER IS POWERED DOWN. CONTACT RATING IS: 0.5A @ 125VAC/VDC RESISTIVE
  - WHEN REMOTE SENSE IS USED, THE VOLTAGE SENSE LEADS RUN FROM R14 TO REMOTE SENSE(-), AND FROM TB5-2 TO REMOTE SENSE(+). REFER TO CONNECTION DIAGRAM FOR WIRING DETAILS.
  - INPUT POWER ISOLATION TRANSFORMER (T1) IS FIELD RE-TAPPABLE FOR 120, 208, OR 240 VAC. SEE TABLE ABOVE.
  - 12, 24 & 48VDC UNITS FEATURE A SINGLE-POLE DC CIRCUIT BREAKER IN THE NEGATIVE BUS AS STANDARD.

- FEATURED OPTIONS:
- STANDARD DC OUTPUT FILTERING
  - BATTERY ELIMINATOR FILTER CAP
  - AC INPUT CIRCUIT BREAKER (MED/HI INT CAPACITY)
  - DC OUTPUT CIRCUIT BREAKER (MED/HI INT CAPACITY)
  - AUXILIARY ALARM RELAY PC BOARD
  - AC INPUT LIGHTNING ARRESTOR
  - EXTERNAL TEMPCO REMOTE PROBE
  - COMMUNICATIONS MODULE

THIRD ANGLE PROJECTION		DRAWN BY <b>KMW</b> 110121				1075 Saint John Street Easton, PA 18042-6661 PH 610-330-9000 FAX 610-330-8510 www.hindlepowerinc.com	
ELECTRONIC APPROVAL SIGNATURES MAINTAINED BY MFG ECN LOG		TITLE <b>BATTERY CHARGER SCHEMATIC: 6-25ADC W/ COMMON OPTIONS</b>		DRAWING No <b>JE5031-21</b>		REV <b>0</b> <b>B</b>	
0	N/A	110121	UNLESS OTHERWISE NOTED, DIMENSIONS ARE IN INCHES. TOLERANCES ARE:		SCALE <b>NTS</b>	SALES No	SHEET <b>1</b> OF <b>1</b>

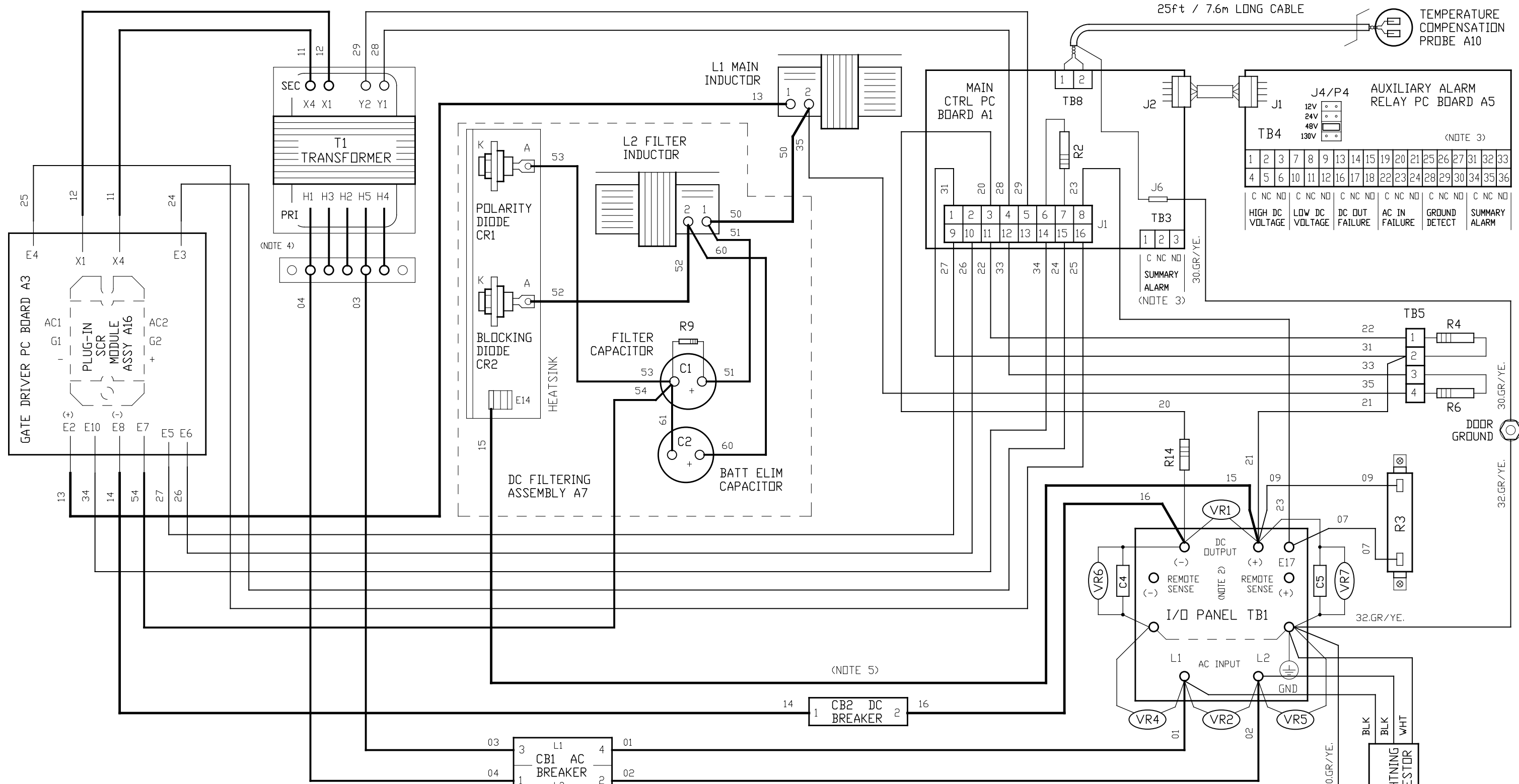

**NOTES:**

- 1) CHARGER COMPONENTS ARE CONNECTED WITH BLACK FLAME-RETARDANT SWITCHBOARD INSULATION SYSTEM (SIS) TYPE WIRING, IDENTIFIED ON EACH END WITH NUMBER-CODED MARKERS. GROUND WIRES #10 & #32 ARE GREEN WITH YELLOW STRIPE.
- 2) WHEN REMOTE SENSE IS USED, THE LUGGED END OF R14 CONNECTS TO REMOTE SENSE(-), AND WIRE# 21 CONNECTS TB5-2 TO REMOTE SENSE(+).
- 3) STANDARD USER ALARM CONTACTS (TB3, TB4, etc.) ARE SOLDERLESS COMPRESSION SCREW TERMINALS, ACCEPTING #22-14 AWG WIRE.
- 4) SEE SCHEMATIC FOR MULTI-TAP TRANSFORMER (T1) PRIMARY CONNECTION TABLE.
- 5) STANDARD 12, 24 AND 48 VDC UNITS CONTAIN A SINGLE-POLE DC BREAKER (CB2) IN THE NEGATIVE BUS. FOR THESE UNITS, WIRE# 15 TERMINATES AT TB1(+) AND WIRE# 17 IS NOT USED.

**FEATURED OPTIONS:**

- STANDARD DC OUTPUT FILTERING
- BATTERY ELIMINATOR FILTER CAP
- AC INPUT CIRCUIT BREAKER
- DC OUTPUT CIRCUIT BREAKER
- AUXILIARY ALARM RELAY PC BOARD
- AC INPUT LIGHTNING ARRESTOR
- EXTERNAL TEMPCD REMOTE PROBE

			 THIRD ANGLE PROJECTION		 1075 Saint John Street Easton, PA 18042-6661 PH 610-330-9000 FAX 610-330-8510 www.hindlepowerinc.com	
			DRAWN BY <b>KMW</b>		110121	
			ELECTRONIC APPROVAL SIGNATURES MAINTAINED BY MFG ECN LOG			
			UNLESS OTHERWISE NOTED DIMENSIONS ARE IN INCHES. TOLERANCES ARE:			
0	N/A	110121	TITLE			BATTERY CHARGER CONNECTION DIAGRAM: 6-25ADC W/ COMMON OPTIONS
REV	ECN No	DATE	DRAWING No			JE5033-21
			SCALE			NTS
			SALES No			
			SHEET			1 OF 1

NOTES:

- 1) FOR COMPLETE MANUAL OF AT SERIES COMMUNICATIONS MODULE OPTION, SEE OPERATING INSTRUCTIONS: JA0102-04.pdf
- 2) SEE TABLE BELOW FOR USER CONNECTIONS.

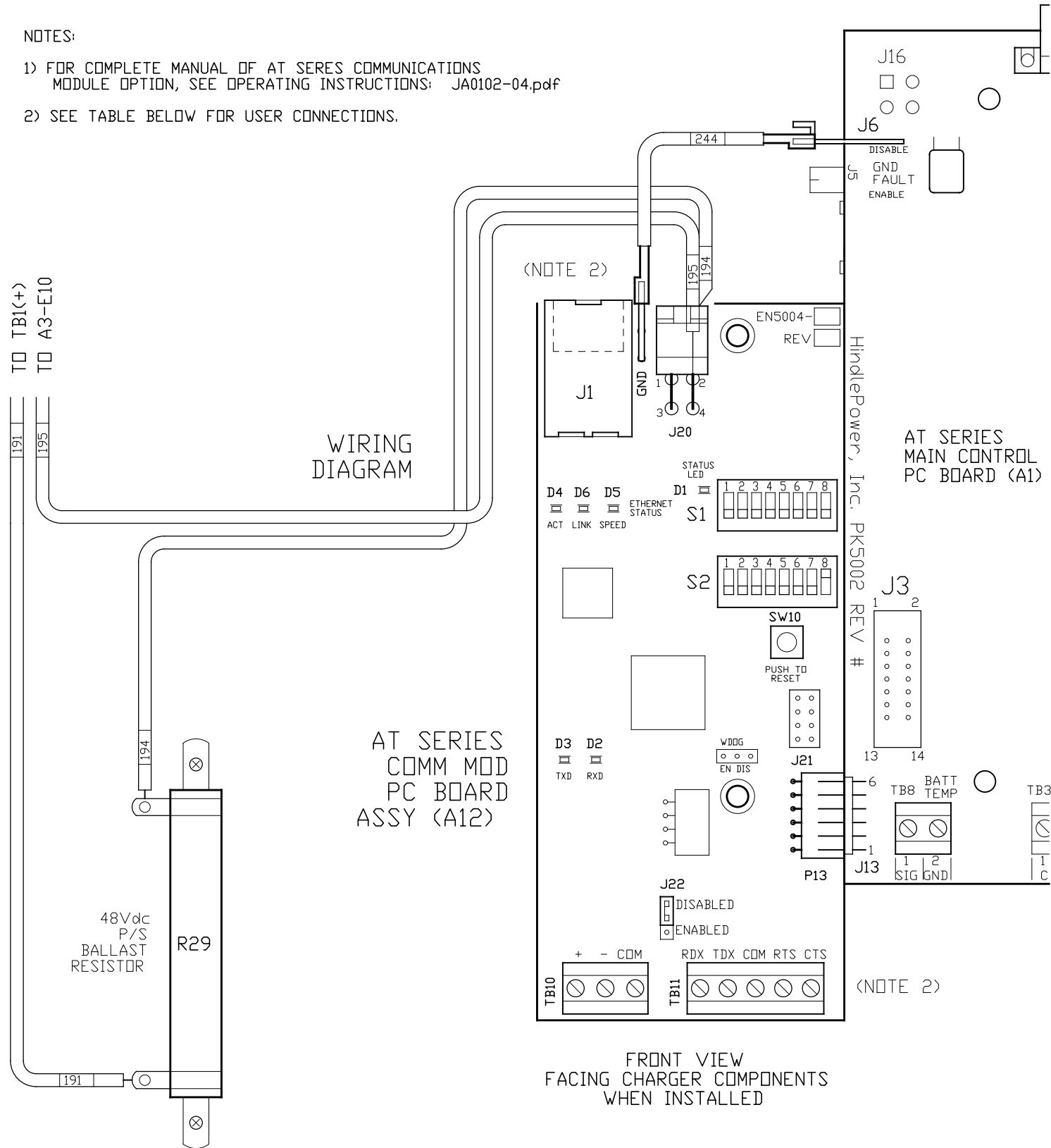

SIDE VIEW OF PC BOARD

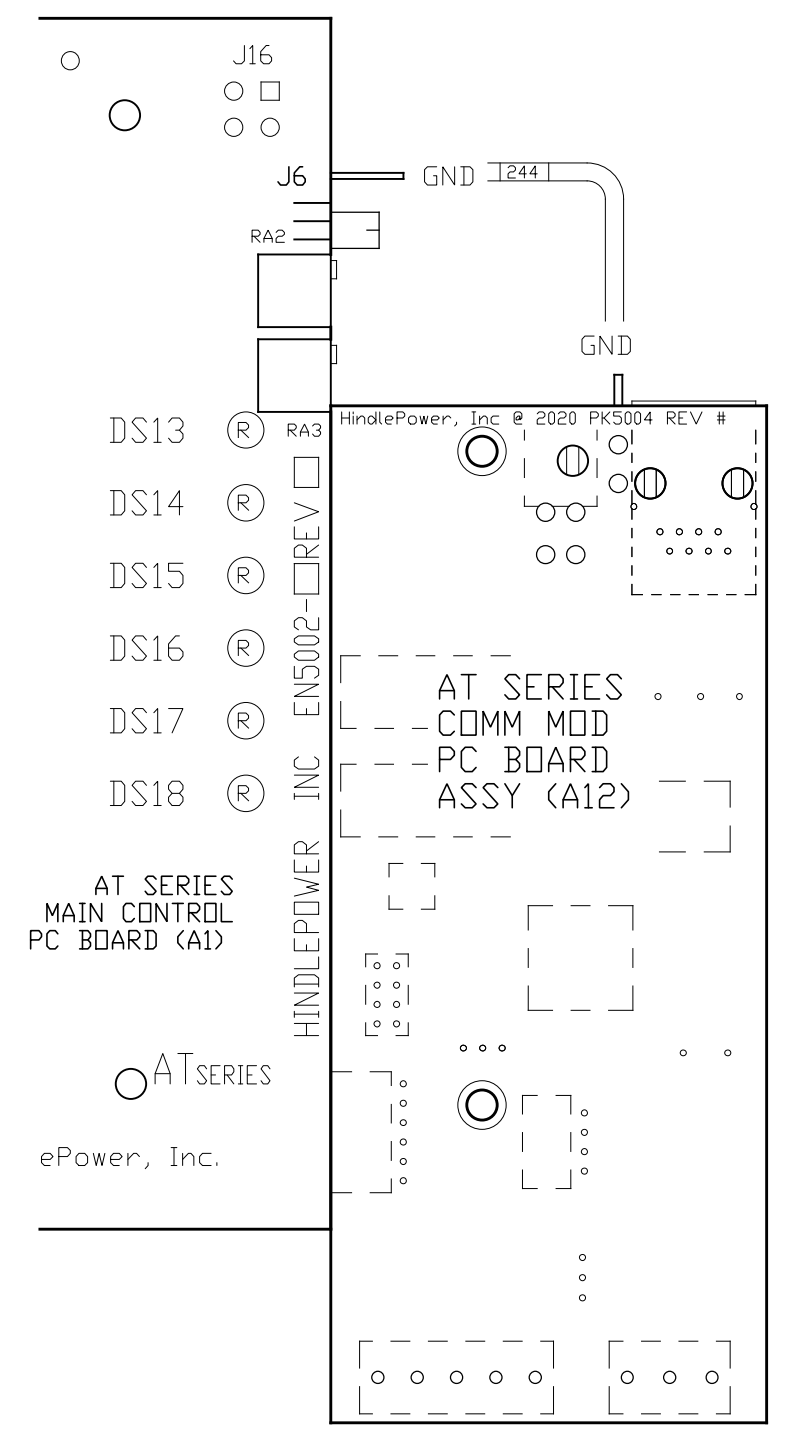
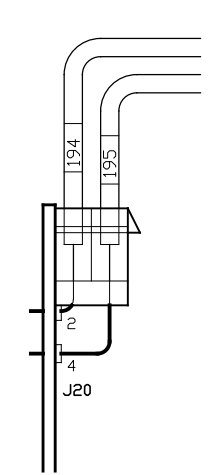

BACK VIEW FACING CHARGER DOOR WHEN INSTALLED

- INDICATOR LIGHTS:
- D1 - STATUS LED, SPI COMM
  - D2 - RXD, SERIAL RECEIVE LED
  - D3 - TXD, SERIAL TRANSMIT LED
  - D4 - ACT, ETHERNET ACTIVITY LED
  - D5 - SPEED, ETHERNET 10/100 LED
  - D6 - LINK, ETHERNET STATUS LED
- JUMPERS / CONNECTORS:
- J20 - POWER SUPPLY CONNECTION
  - J21 - FACTORY CONNECTION
  - J22 - RS-485 TERMINATING RESISTOR (ENABLE/DISABLE)
  - P13 - PLUG FOR MAIN CONTROL PCB (A1) (J13 CONNECTION)
- SWITCHES:
- S1 - CONFIGURATION SWITCHES
  - S2 - MODBUS ADDRESS
  - SW10 - RESET BUTTON

I/O TERMINAL	DESCRIPTION - TYPE	CONNECTION
TB10	RS-485 SERIAL TERMINALS - SOLDERLESS COMPRESSION SCREW	#22-14 AWG
TB11	RS-232 SERIAL TERMINALS - SOLDERLESS COMPRESSION SCREW	#22-14 AWG
J1	ETHERNET SERIAL TERMINAL - RJ45 SOCKET	CAT 5,6 UTP
GND	PC BOARD GROUND TERMINAL - SLIP-ON TAB	QC LUG

				1075 Saint John Street Easton, PA 18042-6661 PH 610-330-9000 FAX 610-330-8510 www.hindlepowerinc.com	
		DRAWN BY		TITLE AT SERIES BATTERY CHARGER COMMUNICATION MODULE OPTION DETAIL	
0		ELECTRONIC APPROVAL SIGNATURES MAINTAINED BY MFG ECN LOG		DRAWING No JE5107-21	
REV		ECN No		DATE	
SCALE NTS		SALES No		SHEET 1 OF 1	