

FRONT VIEW

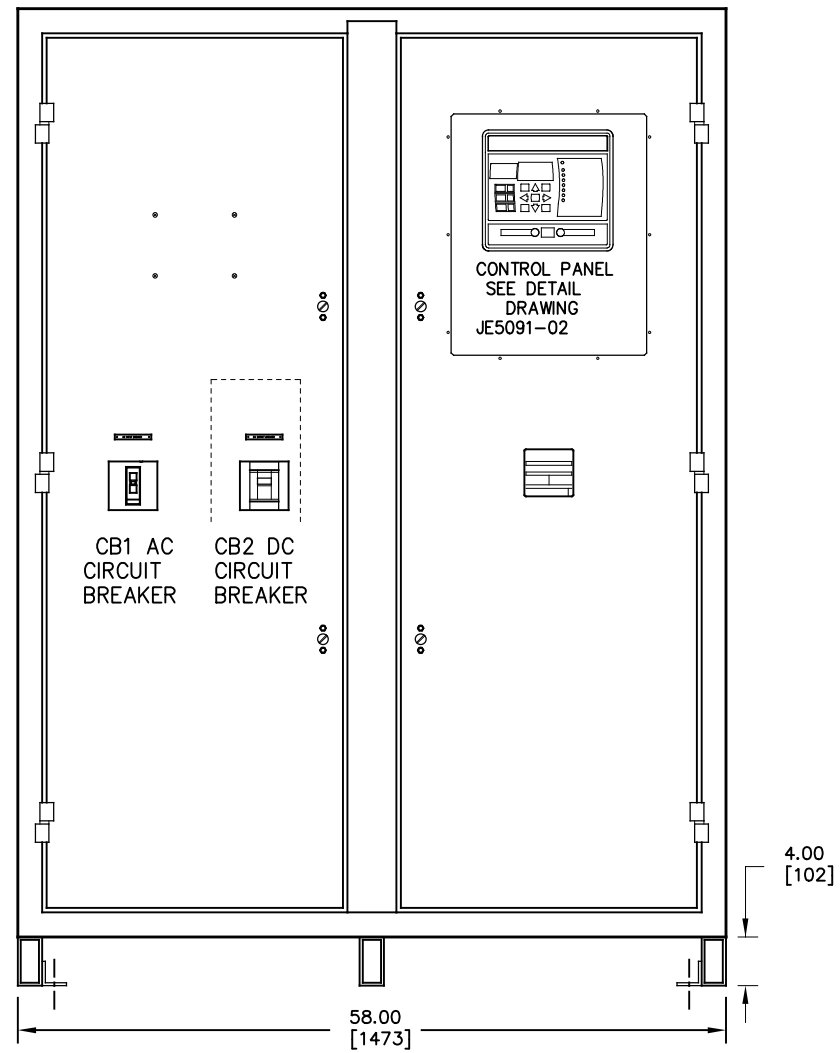

RIGHT SIDE VIEW

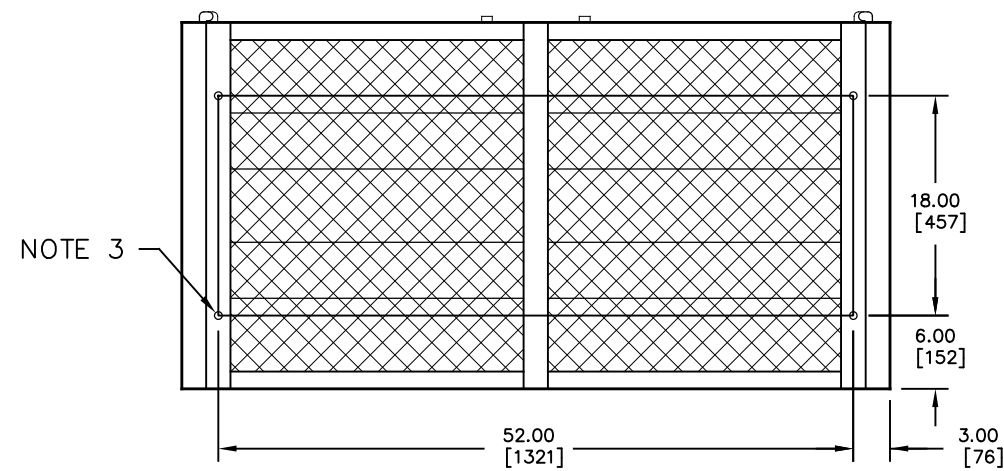
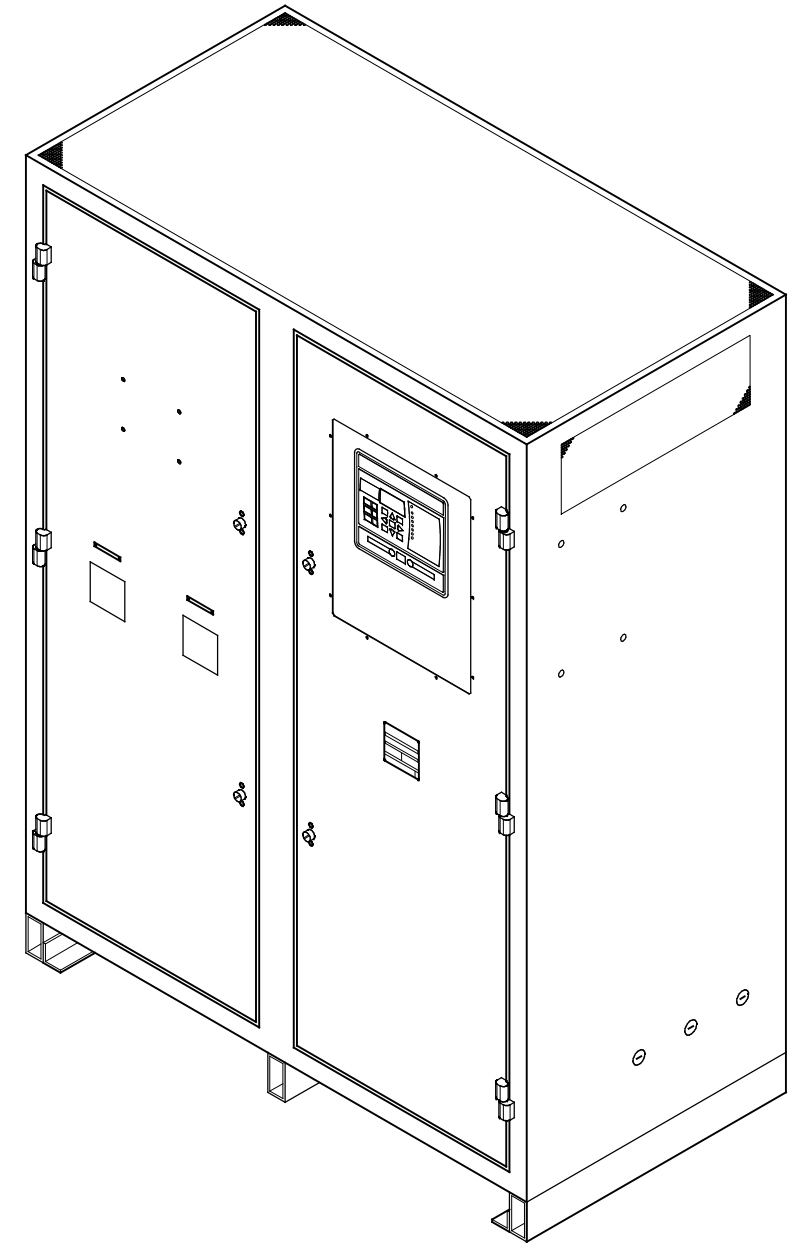
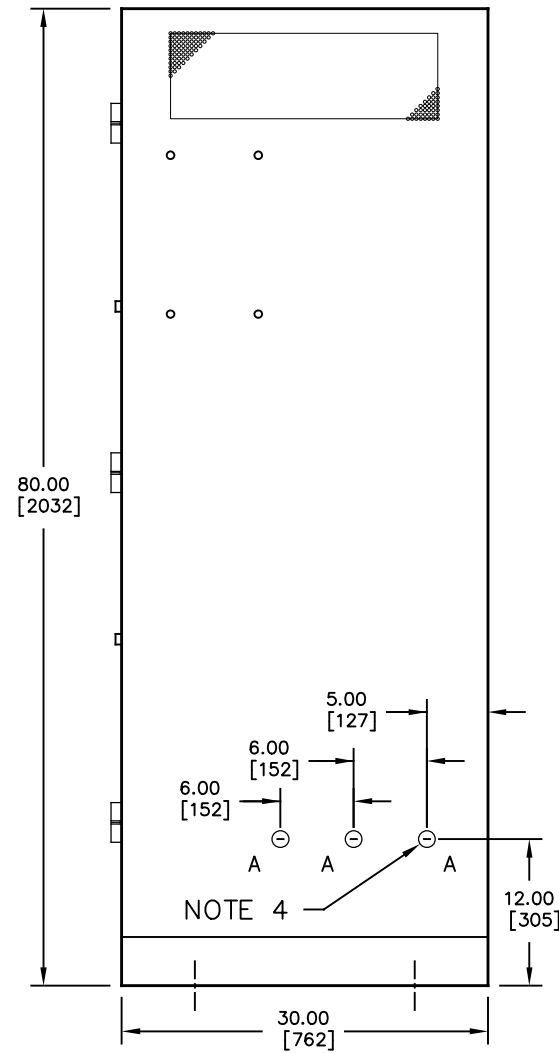

BOTTOM VIEW

NOTES:

- 1) ENCLOSURE IS A NEMA TYPE 1 / IP20 TOP-VENTED STEEL CABINET WITHOUT GASKETS. FINISH IS ANSI-61 GRAY EPOXY POWDERCOAT.
- 2) ALLOW 6in / 152mm OF FREE AIR ON ALL VENTED SURFACES (TOP, SIDES & REAR) FOR COOLING.
- 3) FOUR (4) 0.625in / 16mm FLOOR-MOUNTING HOLES ARE PROVIDED ON BOTTOM OF ENCLOSURE AS SHOWN.
- 4) SIX (6) STANDARD PRE-FAB CONDUIT KNOCKOUTS ARE PROVIDED AS SHOWN FOR CABLE ENTRY. BOTTOM AND TOP CONDUIT ENTRY IS POSSIBLE THROUGH EXPANDED METAL UNDERSIDE AND FULLY VENTED TOP. IF ADDITIONAL CONDUIT ENTRANCES ARE REQUIRED, ENCLOSURE SHOULD BE FIELD-MODIFIED BY INSTALLER.
- 5) BATTERY CHARGER SHIPPING WEIGHT: APPROXIMATELY TBD lb / TBD kg

HOLE	DIA.	QTY.	APPLICATION
A	1.313 33.34	6	PRE-FAB CONDUIT KNOCKOUT FOR SML CABLE (BOTH SIDES)

REV. DRN BY	CHK BY	APP BY	DATE	DRN BY	DATE	
0	KJB	MCR	MCR	11/01/2021	KJB	11/01/2021
DESCRIPTION				CHK BY	DATE	
STANDARD DRAWINGS.				MCR	11/01/2021	
ECN NO. #ECN#				CHK BY	DATE	
				MCR	11/01/2021	

HINDLEPOWER
 1075 Saint John Street
 Easton, PA 18042-6661
 PH 610-330-9000 FAX 610-330-8510
 www.hindlepowerinc.com

ATEVO BATTERY CHARGER
OUTLINE: NEMA-1 STYLE-198 ENCL
3Ø W/O OPTIONS 300-1000A

B	SCALE	NTS	DWG No	JE5351-02	REV	SHEET
					0	1 OF 1

DUAL DIMENSIONS in mm

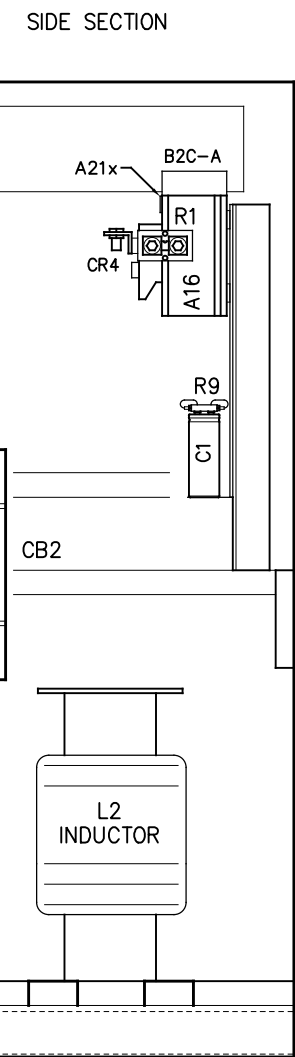
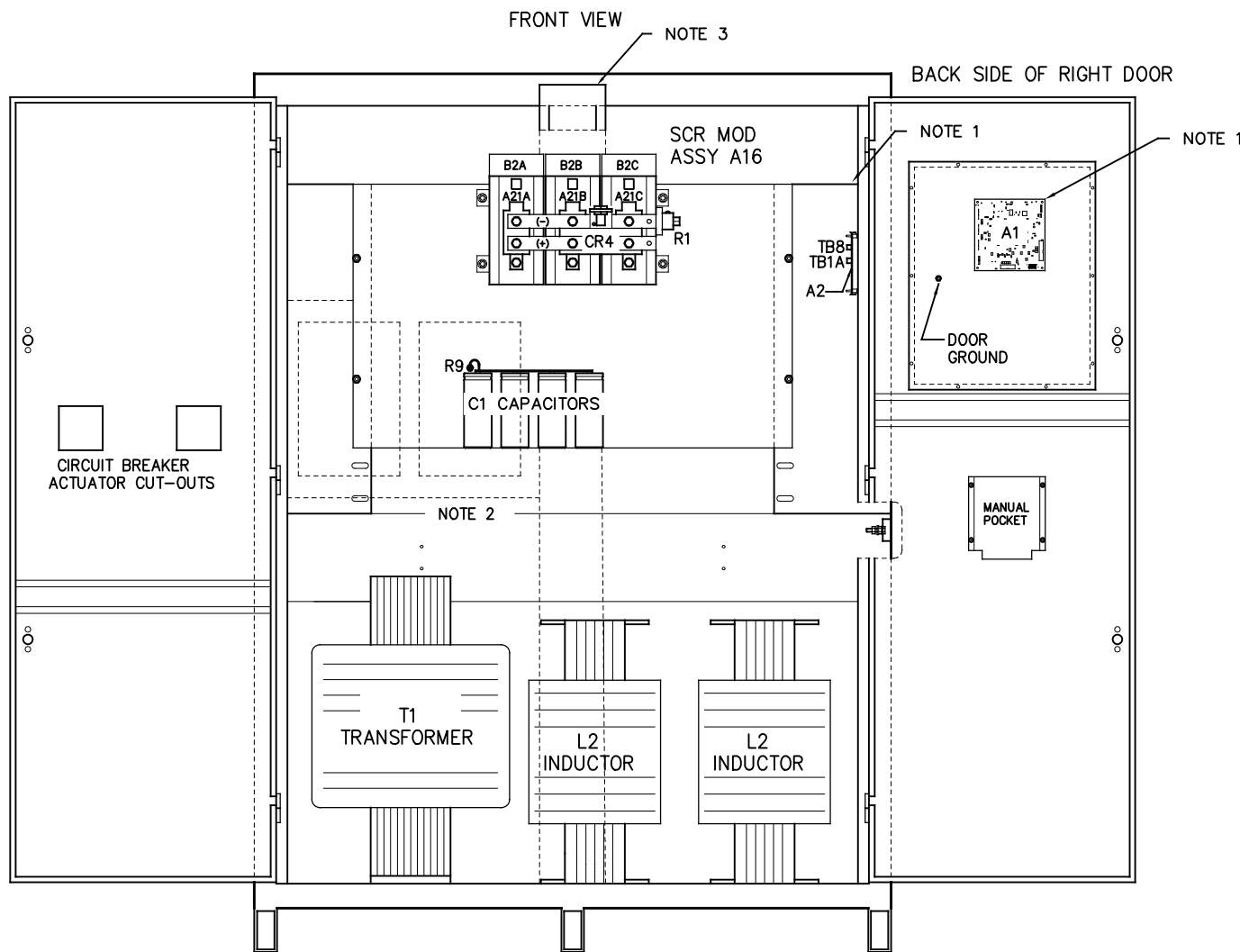

SYM	STANDARD COMPONENT DESCRIPTION
A1	MAIN CONTROL PC BOARD
A2	POWER BOARD
A9	MOV PC BOARD
A16	3PH SCR MODULE ASSY (1x6 Q1-Q6)
A21X	RECTIFIER TEMPERATURE BOARD
B2x	SCR MODULE (A16) COOLING FAN
C1x	DC OUTPUT FILTER CAPACITOR
CB1	AC INPUT CIRCUIT BREAKER (LAL3)
CB2	DC OUTPUT CIRCUIT BREAKER (LGL2)
AUXCB2	DC CKT BKR (CB2) AUXILIARY CONTACTS
CR1	POLARITY DIODE
CR4	FREE-WHEELING DIODE
E13	INDUCTOR INTER-CONNECT POINT
L1	MAIN INDUCTOR
L2	FILTER INDUCTOR
R1	MAIN DC SHUNT, NEG(-) BUS
R9	FILTER CAP (C1) BLEED RESISTOR
T1	POWER ISOLATION TRANSFORMER
TB6	SUMMARY ALARM CONTACTS
TB8	OPT. TEMPCO PROBE TERM BLOCK

- NOTES:
- FOR DETAIL VIEWS OF ALL PC BOARDS (A1, A2, etc.) SEE DRAWING JE5353-02.
 - CIRCUIT BREAKER(S) MOUNTED ON SIDE BRACKET, NOT FULLY SHOWN FOR CLARITY.
 - CENTER DIVIDER NOT SHOWN FOR CLARITY OF INTERNAL VIEW.
 - USER AC INPUT TERMINALS:
 - UTILIZES TOP OF AC OUTPUT BREAKER (CB1)
 - FOUR (3) REMOVABLE ALUMINUM COMPRESSION LUGS
 - TOTAL OF THREE (3) 4 AWG-4/0 WIRES
 - USER DC OUTPUT TERMINALS:
 - UTILIZES TOP OF DC OUTPUT BREAKER (CB2)
 - FOUR (4) REMOVABLE ALUMINUM COMPRESSION LUGS
 - TWO (2) LUGS PER POLE (+/-)
 - TWO (2) USER CONNECTIONS PER LUG
 - TOTAL OF EIGHT (8) 2/0-500 MCM WIRES

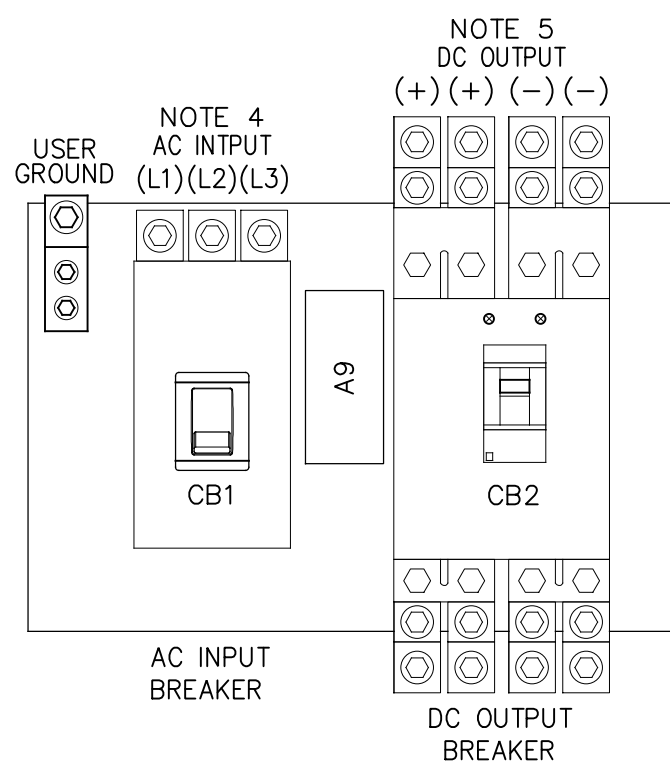

I/O TERMINAL	DESCRIPTION - TYPE	CONNECTION
CB2(+)	POS(+) OUTPUT TERMINAL - DC BREAKER TOP AL COMP LUGS	(4) 2/0-500 MCM
CB2(-)	NEG(-) OUTPUT TERMINAL - DC BREAKER TOP AL COMP LUGS	(4) 2/0-500 MCM
TB1-GND	USER GROUND TERMINAL - CU-ALUMINUM COMPRESSION LUG	#6 AWG-350 MCM
CB1(L1,L2,L3)	AC INPUT TERMINALS - AC BREAKER TOP AL COMP LUGS	#4-4/0 AWG
(A1) TB6	SUMMARY ALARM TERMINAL BLOCK (A1) - SLDRLSS COMP SCREW	#22-14 AWG
(A2) TB1	POS/NEG REMOTE SENSE TERMS (A2) - SOLDERLESS COMPRESSION	#22-14 AWG
(A2) TB8	TEMPCO PROBE (A10) TERM BLK - SOLDERLESS COMPRESSION	#22-14 AWG
TB4-AUX	BARRIER TYPE AUX ALARM (A5) CONTACTS - 6-32 COMP SCREW	#16-14 AWG

REV. 0	DRN BY KJB	CHK BY MCR	APP BY MCR	DATE 11/01/2021	DRN BY KJB	DATE: 11/01/2021		1075 Saint John Street Easton, PA 18042-6661 PH 610-330-9000 FAX 610-330-8510 www.hindlepowerinc.com	
DESCRIPTION: STANDARD DRAWINGS.					CHK BY MCR	DATE: 11/01/2021			
ECN NO. #ECN#					CHK BY MCR	DATE: 11/01/2021	TITLE: ATEVO BATTERY CHARGER INTERNAL COMPONENT LAYOUT: STYLE-198 3Ø W/O OPTIONS 300-1000A		
							B SCALE NTS	DWG No JE5352-02	REV 0 SHEET 1 OF 2

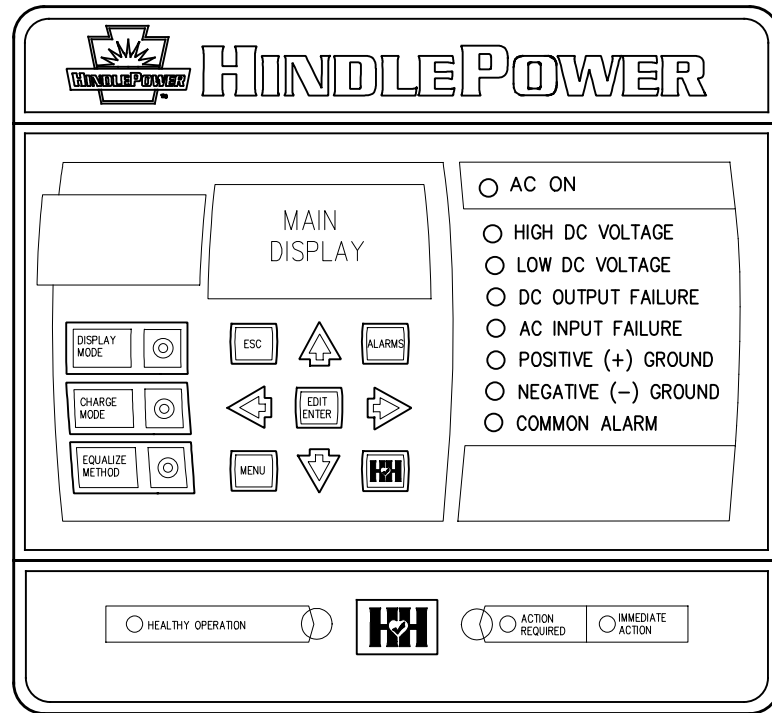

INSTRUMENT PANEL
(PART No. FK5047-00)

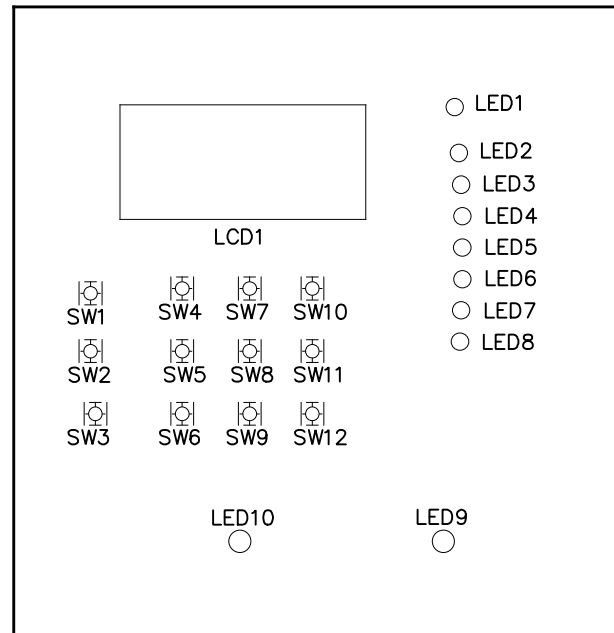

MAIN CONTROL PC BOARD (A1)
FRONT VIEW – FACING CHARGER DOOR WHEN INSTALLED

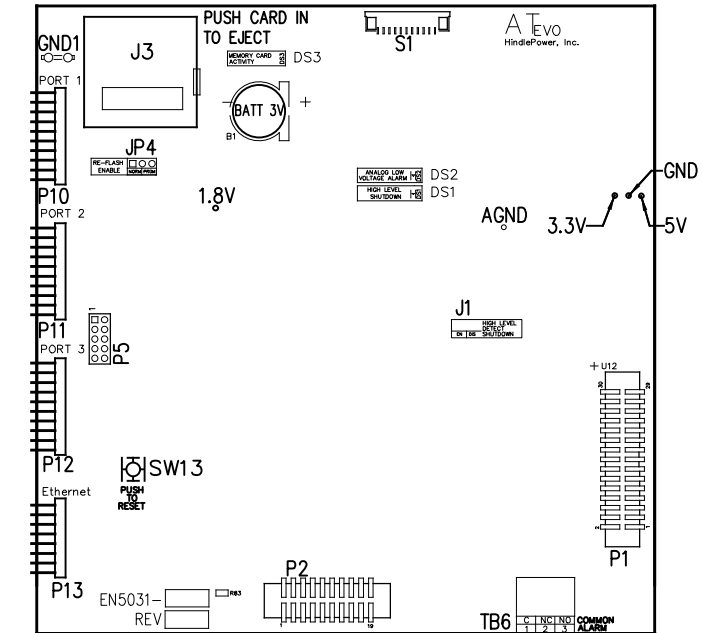

MAIN CONTROL PC BOARD (A1)
BACK VIEW – FACING CHARGER COMPONENTS WHEN INSTALLED

NOTE: ALL ALARM CONTACTS ARE ENERGIZED WHEN IN THE NON-ALARM STATE (FAIL SAFE). ALL ALARM CONTACTS WILL CHANGE STATE WHEN CHARGER IS POWERED DOWN. CONTACT RATING IS 0.5A @ 125VAC/VDC RESISTIVE.

MAIN CONTROL PC BOARD (A1)

INDICATOR LIGHTS (LEDs):

- LED1 – GREEN – AC ON
- LED2 – RED – HIGH DC VOLTAGE ALARM
- LED3 – RED – LOW DC VOLTAGE ALARM
- LED4 – RED – DC OUTPUT FAILURE ALARM
- LED5 – RED – AC INPUT FAILURE ALARM
- LED6 – RED – POSITIVE (+) GROUND ALARM
- LED7 – RED – NEGATIVE (-) GROUND ALARM
- LED8 – RED – COMMON ALARM
- LED9 – RED – ACTION REQUIRED ALARM
- LED10 – GREEN – HEALTHY OPERATION
- DS1 – RED – HIGH LEVEL SHUTDOWN (HLD)
- DS2 – RED – ANALOG LOW VOLTAGE ALARM (LLD)
- DS3 – RED – MEMORY CARD ACTIVITY

JUMPERS:

- J1 – ANALOG HIGH VOLTAGE SHUTDOWN JUMPER
- J3 – SD CARD PORT
- JP4 – RE-FLASH (FIELD PROGRAMMING) JUMPER
- TERMINAL BLOCKS:
- TB6 – COMMON ALARM RELAY CONTACTS
- TEST POINTS:
- 1.8V – 1.8 VOLTS
- 3.3V – 3.3 VOLTS
- 5V – 5.0 VOLTS
- GND – GROUND
- AGND – ANALOG GROUND
- SDA – MAIN BOARD 12C DATA
- SCL – MAIN BOARD 12C CLOCK

SWITCHES:

- S1 – DISPLAY BUTTON
- S2 – CHARGE MODE BUTTON
- S3 – EQUALIZE METHOD BUTTON
- S4 – ESCAPE (ESC) BUTTON
- S5 – LEFT ARROW BUTTON
- S6 – MENU BUTTON
- S7 – UP ARROW BUTTON
- S8 – EDIT / ENTER BUTTON
- S9 – DOWN ARROW BUTTON
- S10 – ALARM BUTTON
- S11 – RIGHT ARROW BUTTON
- S12 – HINDLE HEALTH (HHS) BUTTON
- S13 – SYSTEM RESET BUTTON (BACK OF BOARD)

CONNECTORS:

- P1 – POWER BOARD RIBBON
- P2 – 3 PHASE RECTIFIER RIBBON
- P3 – USB EXPANSION PORT
- P4 – SPI & I2C EXPANSION PORT #1
- P5 – SPI & I2C EXPANSION PORT #2
- P6 – DISPLAY SPI PORT
- P7 – DISPLAY JTAG PORTS
- P10 – SERIAL INTERFACE PORT #1
- P11 – SERIAL INTERFACE PORT #2
- P12 – SERIAL INTERFACE PORT #3
- P13 – ETHERNET INTERFACE PORT
- P17 – GENERAL EXPANSION PORT

I/O TERMINAL	DESCRIPTION – TYPE	CONNECTION
(A1) TB6	SUMMARY ALARM TERMINAL BLOCK (A1) – SOLDERLESS COMPRESSION SCREW	#22-14 AWG CAT5
(A22) J1	SERIAL ETHERNET CONNECTION – RJ45 PLUG	

REV. 0	DRN BY KJB	CHK BY MCR	APP BY MCR	DATE 11/01/2021	DRN BY KJB	DATE: 11/01/2021	<p>1075 Saint John Street Easton, PA 18042-6661 PH 610-330-9000 FAX 610-330-8510 www.hindlepowerinc.com</p>
DESCRIPTION: STANDARD DRAWINGS.					CHK BY MCR	DATE: 11/01/2021	
ECN NO. #ECN#					CHK BY MCR	DATE: 11/01/2021	
<p>TITLE: ATEVO BATTERY CHARGER INSTRUMENT PANEL / PC BOARD DETAIL 3Ø W/O OPTIONS 300-1000A</p>							
<p>SCALE: B DWG No: JE5353-02</p>							REV 0 SHEET 1 OF 2

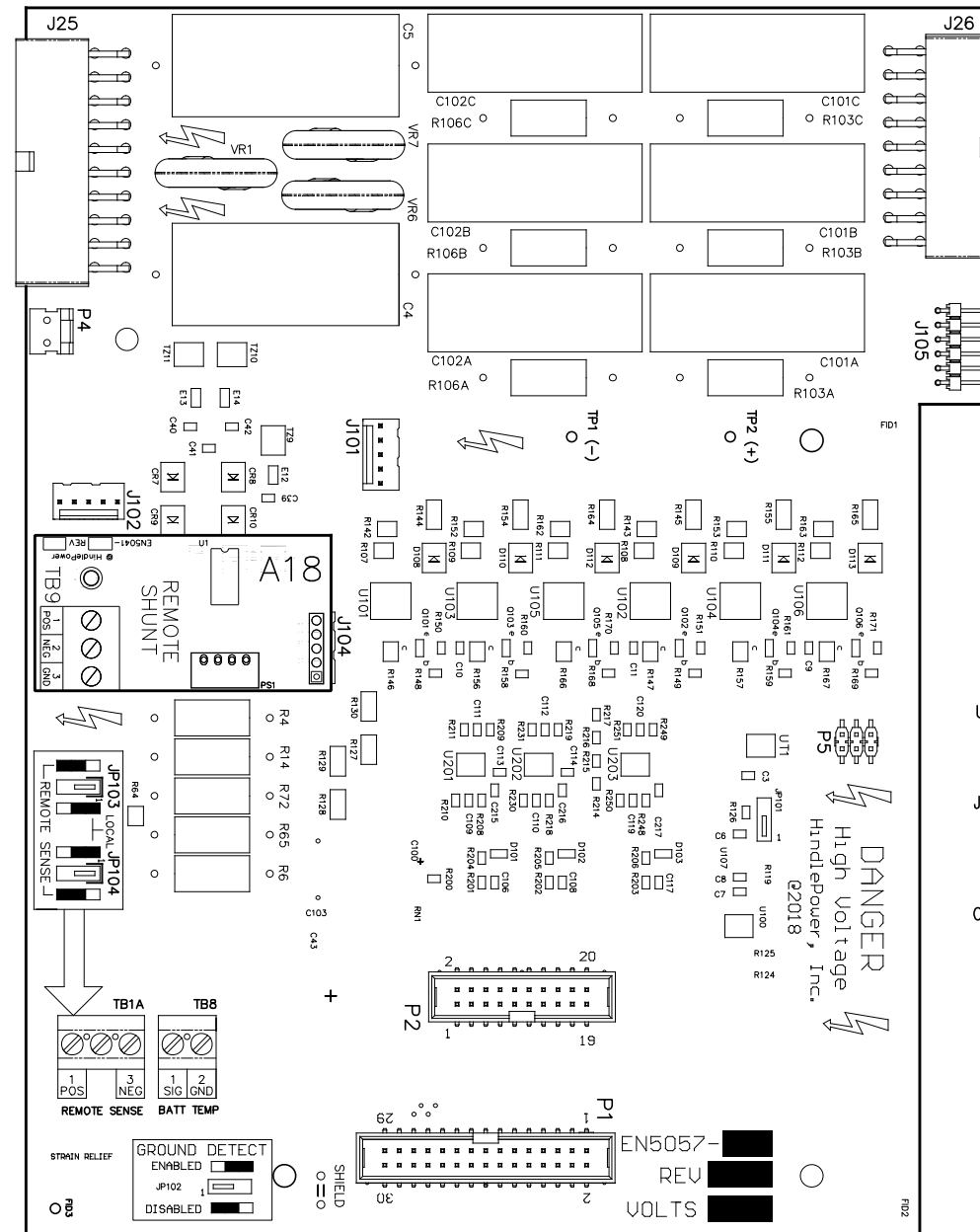

- USER TERMINALS ON POWER BOARD (A2):
 TB1 - REMOTE VOLTAGE SENSE
 TB8 - BATTERY TEMPERATURE COMPENSATION
- JUMPERS ON POWER BOARD (A2):
 JP102 - GROUND DETECT CIRCUIT ENABLE / DISABLE
 JP103 - REMOTE OR LOCAL SENSE SELECTOR (+)
 JP104 - REMOTE OR LOCAL SENSE SELECTOR (-)
- CONNECTORS ON POWER BOARD (A2):
 J1 - POWER OUT
 J25 - MAIN CONTROL SIGNAL HARNESS
 J26 - SCR FIRING CONTROL HARNESS
 J101 - DC POWER SUPPLY
 J102 - DC POWER SUPPLY
 J104 - BATTERY SHUNT
 J105 - AUXILIARY I/O BOARD
 P1 - MAIN CONTROL BOARD RIBBON 1
 P2 - MAIN CONTROL BOARD RIBBON 2
 P4 - CB1 AUX
 P5 - RECTIFIER TEMP SENSOR INTERFACE
- TEST POINTS ON POWER BOARD (A2):
 TP1 - PRE-FILTERED DC BUS (-)
 TP2 - PRE-FILTERED DC BUS (+)

POWER BOARD (A2)

I/O TERMINAL	DESCRIPTION - TYPE	CONNECTION
(A2) TB1	POS/NEG REMOTE SENSE TERMS (A2) - SOLDERLESS COMPRESSION SCREW	#22-14 AWG
(A2) TB8	TEMPCO PROBE (A10) TERM BLK - SOLDERLESS COMPRESSION SCREW	#22-14 AWG

DRN BY KJB	DATE: 11/01/2021		1075 Saint John Street Easton, PA 18042-6661 PH 610-330-9000 FAX 610-330-8510 www.hindlepowerinc.com			
CHK BY MCR	DATE: 11/01/2021		TITLE ATEVO BATTERY CHARGER INSTRUMENT PANEL / PC BOARD DETAIL 3Ø WITH COMMON OPTIONS 300-1000A			
CHK BY MCR	DATE: 11/01/2021					
		B	SCALE NTS	DWG No JE5353-02	REV 0A	SHEET 2 OF 2

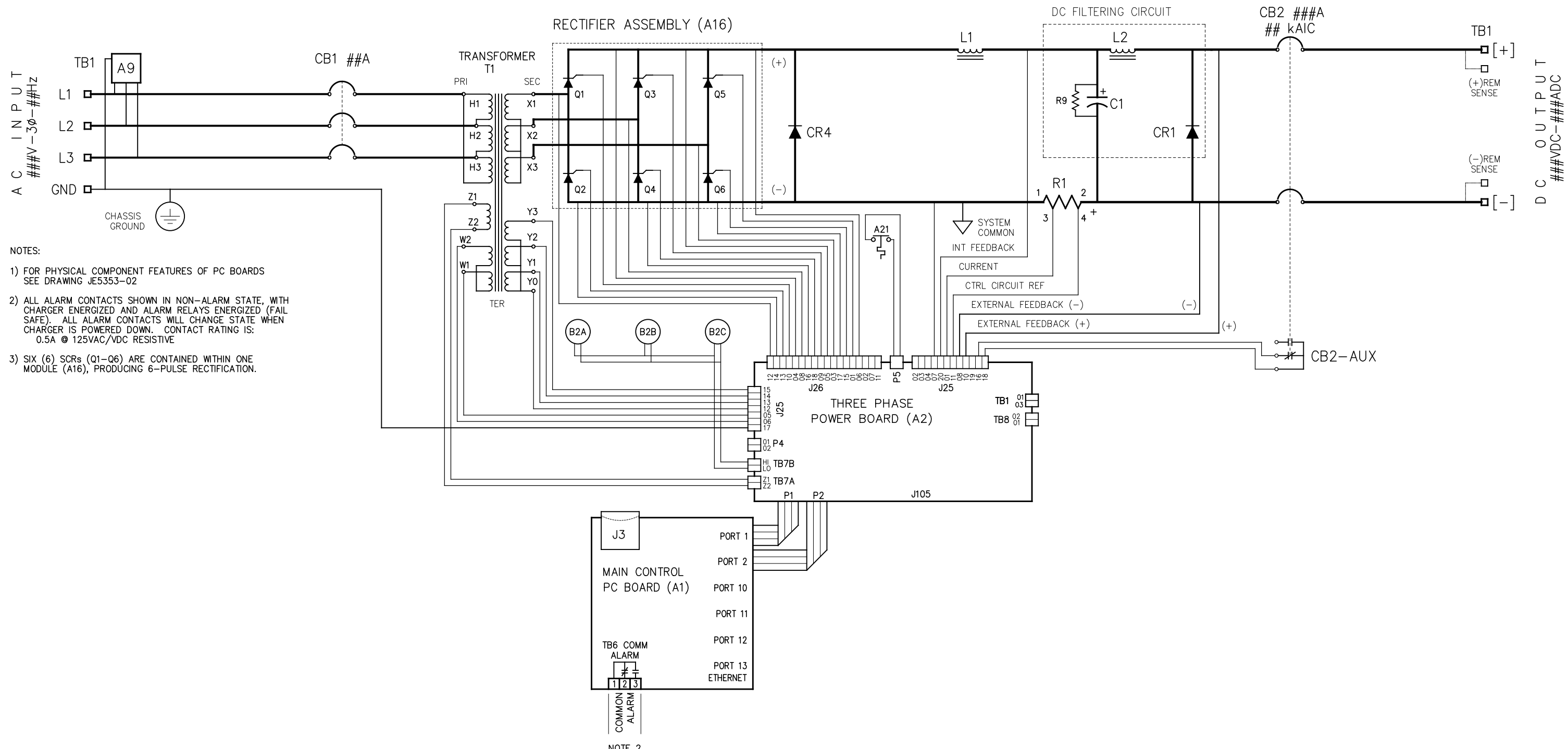

- NOTES:
- 1) FOR PHYSICAL COMPONENT FEATURES OF PC BOARDS SEE DRAWING JE5353-02
 - 2) ALL ALARM CONTACTS SHOWN IN NON-ALARM STATE, WITH CHARGER ENERGIZED AND ALARM RELAYS ENERGIZED (FAIL SAFE). ALL ALARM CONTACTS WILL CHANGE STATE WHEN CHARGER IS POWERED DOWN. CONTACT RATING IS: 0.5A @ 125VAC/VDC RESISTIVE
 - 3) SIX (6) SCRs (Q1-Q6) ARE CONTAINED WITHIN ONE MODULE (A16), PRODUCING 6-PULSE RECTIFICATION.

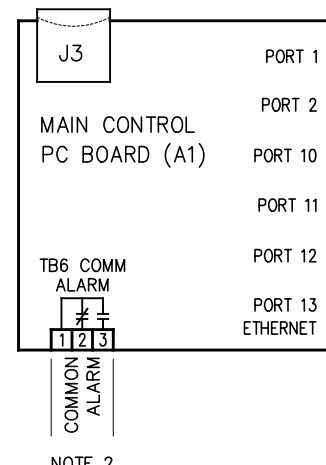

NOTE 2

REV. 0	DRN BY KJB	CHK BY MCR	APP BY MCR	DATE 11/01/2021	DRN BY KJB	DATE: 11/01/2021		1075 Saint John Street Easton, PA 18042-6661 PH 610-330-9000 FAX 610-330-8510 www.hindlepowerinc.com
DESCRIPTION STANDARD DRAWINGS.					CHK BY MCR	DATE: 11/01/2021		
ECN NO. #ECN#					CHK BY MCR	DATE: 11/01/2021	TITLE ATEVO BATTERY CHARGER SCHEMATIC: STYLE 198 3φ WITH COMMON OPTIONS 300-1000A	
							B	SCALE NTS DWG No JE5354-02 REV 0A SHEET 1 OF 1

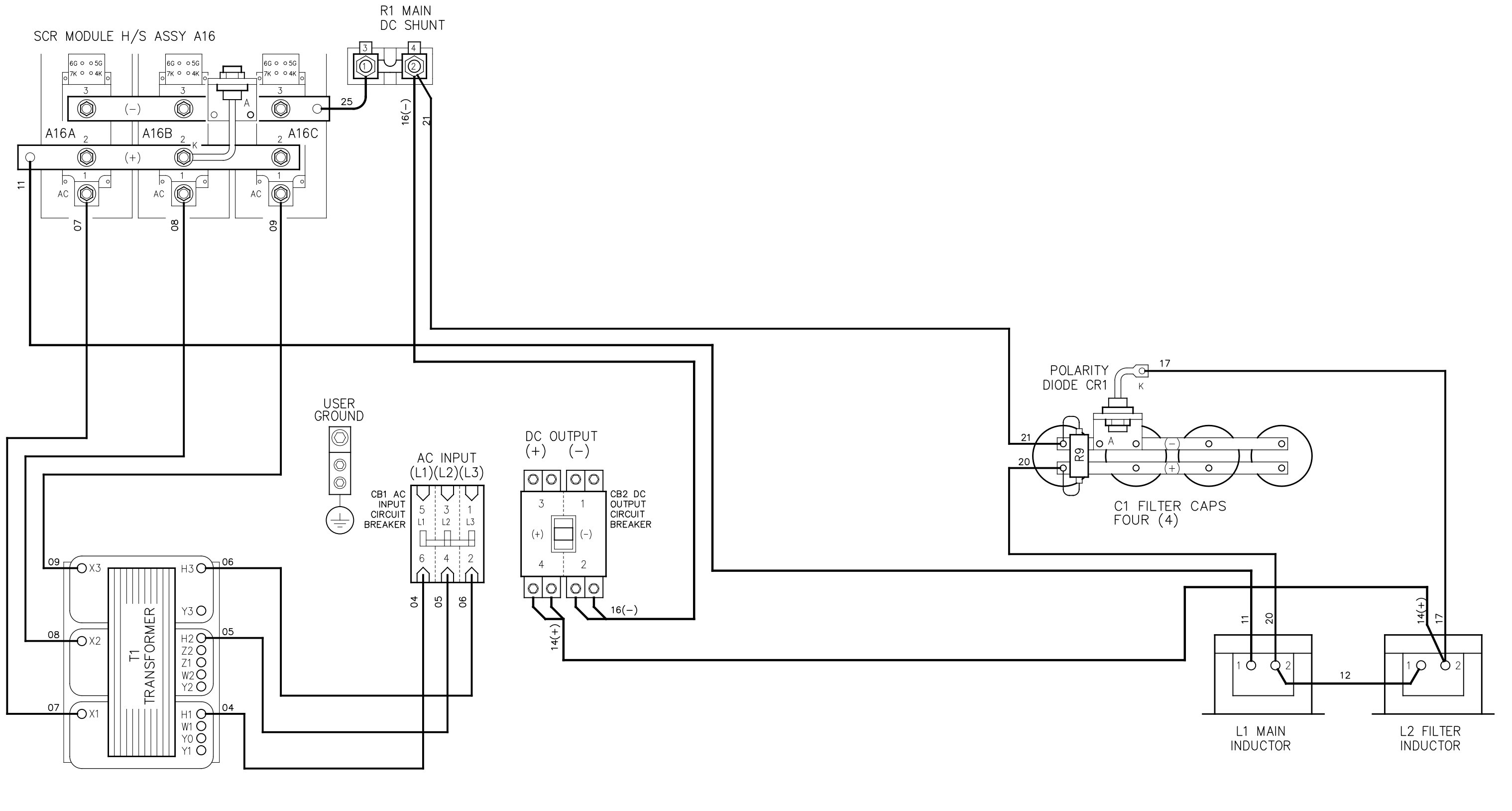

NOTES:

- CHARGER COMPONENTS ARE CONNECTED WITH FLAME-RETARDANT SWITCHBOARD INSULATION SYSTEM (SIS) TYPE WIRING, IDENTIFIED ON EACH END WITH NUMBER-CODED MARKERS. GROUND WIRE #10 IS GREEN WITH YELLOW STRIPE.
- THIS DRAWING (SHEET 1 OF 3) SHOWS MAINFRAME POWER WIRING. SEE SUBSEQUENT SHEETS FOR:
 - SHEET 2 OF 3 - SENSE (SIGNAL) WIRING.
 - SHEET 3 OF 3 - SCR (A16x) TRIGGER WIRING

REV. 1	DRN BY KJB	CHK BY MCR	APP BY MCR	DATE 12/2/2021	DRN BY KJB	DATE 11/01/2021		1075 Saint John Street Easton, PA 18042-6661 PH 610-330-9000 FAX 610-330-8510 www.hindlepowerinc.com
DESCRIPTION UPDATED CAP WIRING.					CHK BY MCR	DATE 11/01/2021		
ECN NO. #ECN#					CHK BY MCR	DATE 11/01/2021	TITLE ATEVO BATTERY CHARGER CONNECTION DIAGRAM: STYLE 198 3φ WITH COMMON OPTIONS 300-1000A	
							B	SCALE NTS DWG No JE5355-02 REV 1 SHEET 1 OF 3

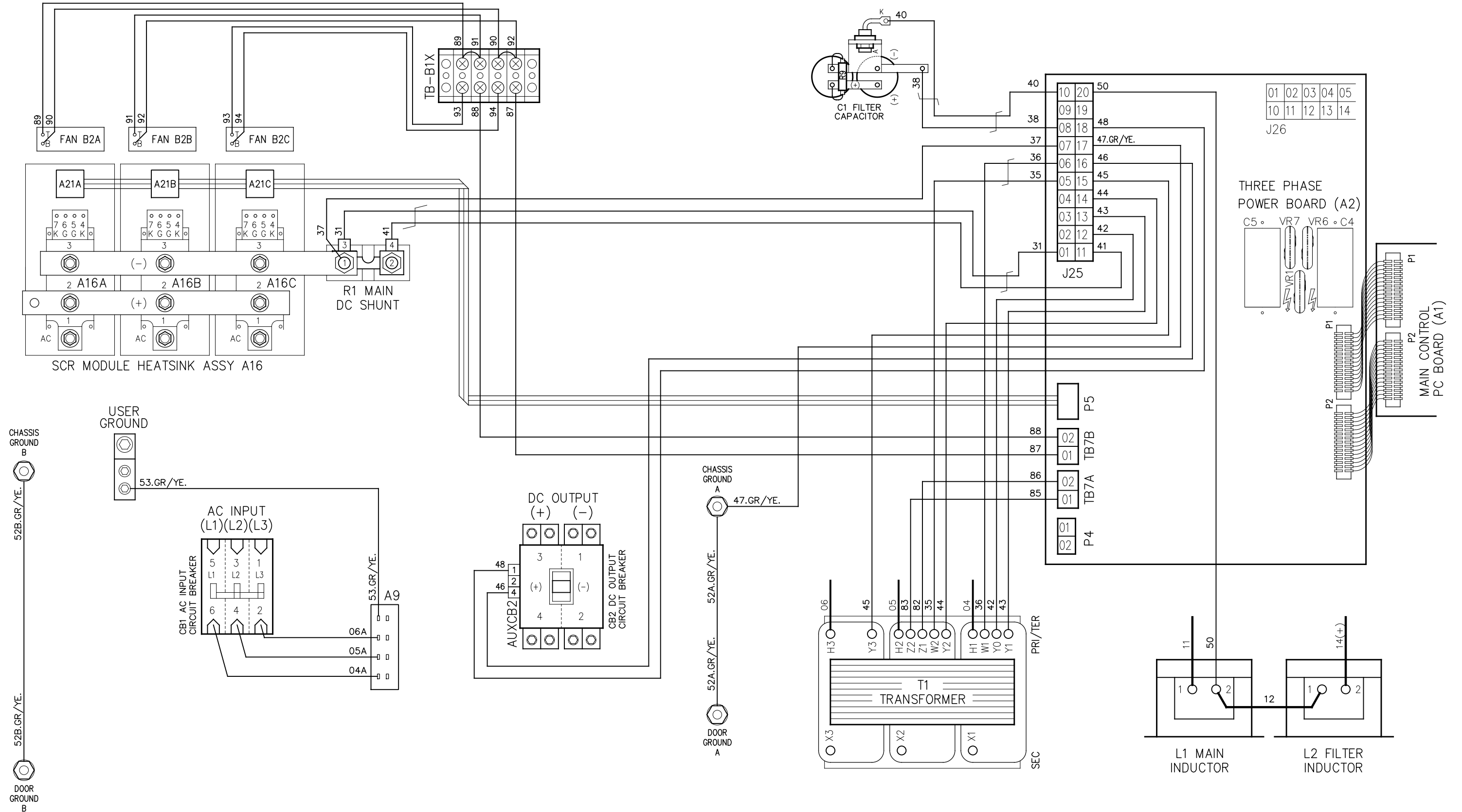

NOTES:

1. CHARGER COMPONENTS ARE CONNECTED WITH FLAME-RETARDANT SWITCHBOARD INSULATION SYSTEM (SIS) TYPE WIRING, IDENTIFIED ON EACH END WITH NUMBER-CODED MARKERS. GROUND WIRE #10 IS GREEN WITH YELLOW STRIPE.
2. THIS DRAWING (SHEET 2 OF 3) SHOWS SENSE (SIGNAL) WIRING, SEE SUBSEQUENT SHEETS FOR:
 - SHEET 1 OF 3 - MAINFRAME POWER WIRING
 - SHEET 3 OF 3 - SCR (A16x) TRIGGER WIRING

DRN BY KJB	DATE: 11/01/2021		1075 Saint John Street Easton, PA 18042-6661 PH 610-330-9000 FAX 610-330-8510 www.hindlepowerinc.com			
CHK BY MCR	DATE: 11/01/2021		ATEVO BATTERY CHARGER CONNECTION DIAGRAM: STYLE 198 3Ø WITH COMMON OPTIONS 300-1000A			
CHK BY MCR	DATE: 11/01/2021		TITLE ATEVO BATTERY CHARGER CONNECTION DIAGRAM: STYLE 198 3Ø WITH COMMON OPTIONS 300-1000A			
		B	SCALE NTS	DWG No JE5355-02	REV 1	SHEET 2 OF 3

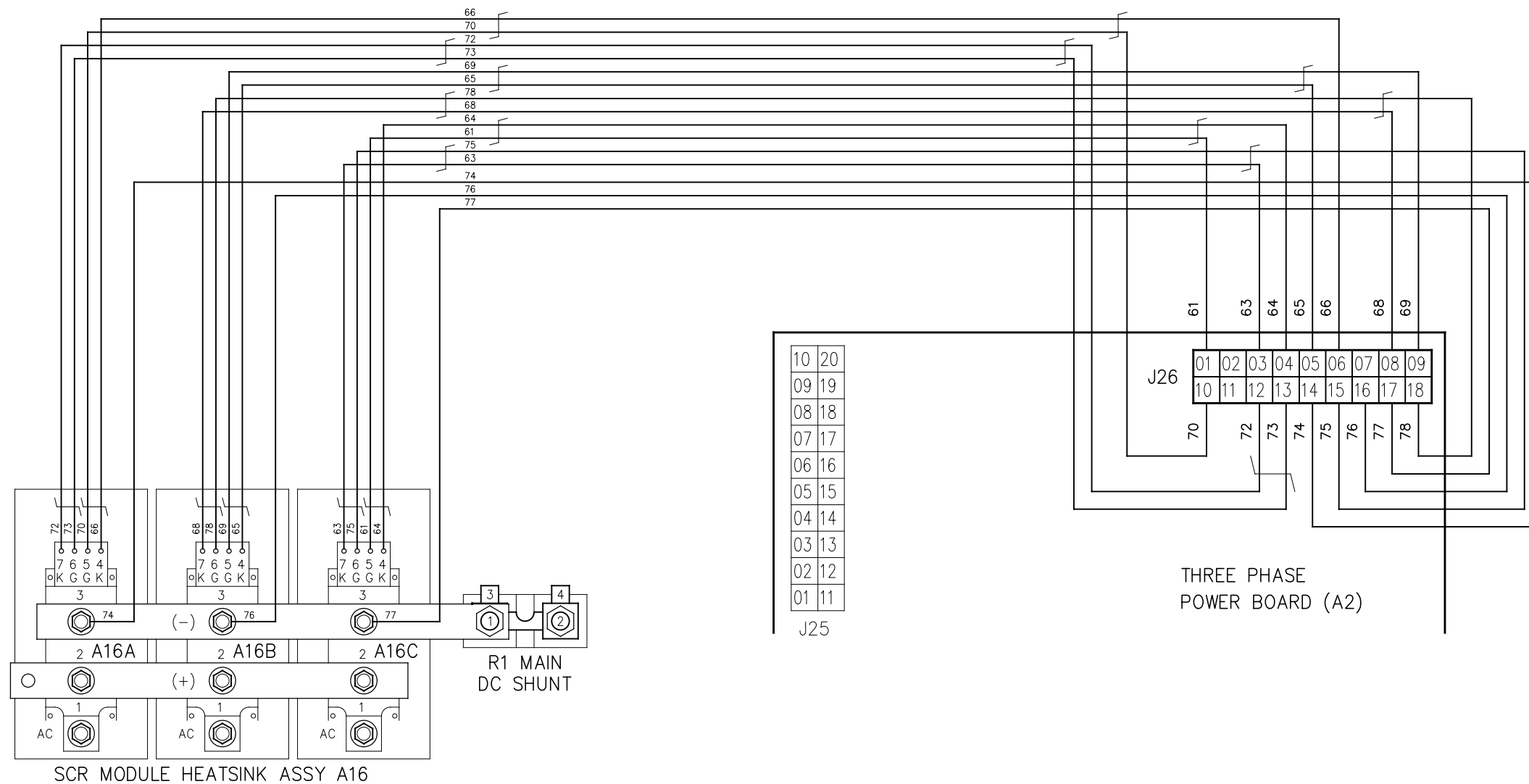

NOTES:

1. CHARGER COMPONENTS ARE CONNECTED WITH FLAME-RETARDANT SWITCHBOARD INSULATION SYSTEM (SIS) TYPE WIRING, IDENTIFIED ON EACH END WITH NUMBER-CODED MARKERS. GROUND WIRE #10 IS GREEN WITH YELLOW STRIPE.
2. THIS DRAWING (SHEET 3 OF 3) SHOWS SCR (A16x) TRIGGER WIRING, SEE SUBSEQUENT SHEETS FOR:
 - SHEET 1 OF 3 - MAINFRAME POWER WIRING
 - SHEET 2 OF 3 - SENSE (SIGNAL) WIRING.

DRN BY KJB	DATE: 11/01/2021	HINDLEPOWER	1075 Saint John Street Easton, PA 18042-6661 PH 610-330-9000 FAX 610-330-8510 www.hindlepowerinc.com			
CHK BY MCR	DATE: 11/01/2021		TITLE ATEVO BATTERY CHARGER CONNECTION DIAGRAM: STYLE 198 3φ WITH COMMON OPTIONS 300-1000A			
CHK BY MCR	DATE: 11/01/2021					
		B	SCALE NTS	DWG No JE5355-02	REV 1	SHEET 3 OF 3