

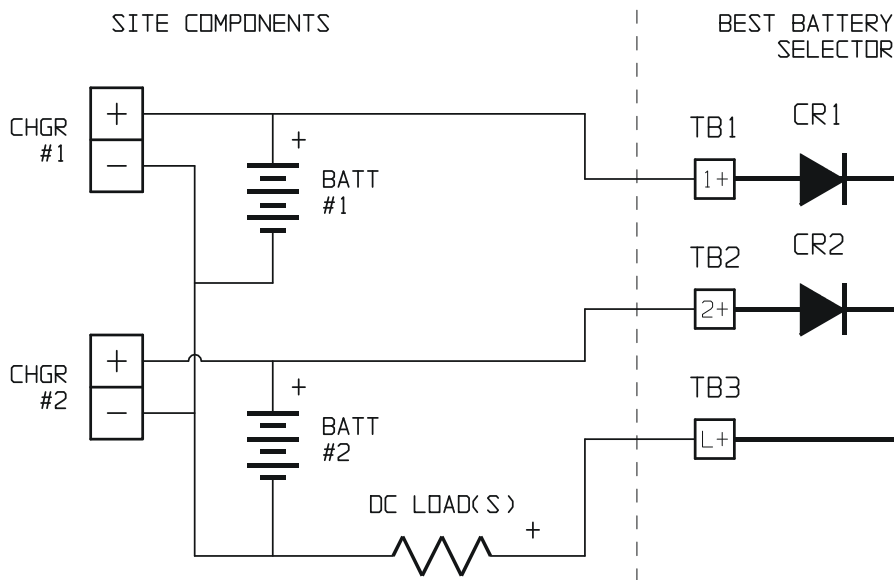

DESCRIPTION

- Industrial applications which require redundant dc power to one (1) **critical** load often consist of two (2) charger / battery sets. When the two (2) systems are tied to a single load, use of the **Best Battery Selector** (BBS) prevents current from flowing from one dc set (charger/battery) to the other. The diodes "steer" the current from the best dc set to the load.
- This assembly is sometimes referred to as "**steering diodes**", or even "**auctioneering diodes**".
- No switching is done. Therefore, the complete system is very reliable. The Best Battery Selector allows the user to test, remove, or repair equipment and/or batteries without disturbing the dc load.
- The Best Battery Selector must be rated to the **maximum** dc load current expected.
- The Best Battery Selector operates along the positive (+) dc bus. No connections are necessary, nor are they supplied, for the negative (-) bus. Refer to **SYSTEM SCHEMATIC** below.
- Without options, there are **no** adjustments, or calibration of the Best Battery Selector.

SYSTEM SCHEMATIC (sample)



INSTALLATION

⚠ CAUTION Dangerous voltages exist at many points inside the enclosure. When performing tasks inside the BBS, be sure to disconnect all input power sources, and lock out breakers and/or safety switches. After dc inputs have been disconnected, wait a minute for charger capacitors to discharge to safe levels before performing internal work. Heatsinks, bus bars, and wire terminals also carry high temperatures. Use extreme care when working inside the Best Battery Selectors. Wear safety gloves while performing this procedure.

STANDARD DRAWINGS (on www.ATSeries.net)

maximum dc output current	50 Adc	100 Adc	200 Adc	500 Adc	750 Adc	1200 Adc
enclosure outline	JE5138-00	JE5138-01	JE5138-02	JE5138-03	JE5138-04	JE5138-05
internal component layout	JE5139-00	JE5139-01	JE5139-02	JE5139-03	JE5139-04	JE5139-05
model number	EJ5144-20, -24	EJ5144-01, -05	EJ5144-02, -06	EJ5144-03, -07	EJ5144-12	EJ5144-14

MOUNTING

- For easiest cable connection, locate a surface near the dc load distribution, or near the charger/batteries.
- The wall or floor mounting surface should be solid, dry, and capable of supporting the weight of the BBS.
- Use 1/4in or 5/16in hardware to wall-mount the enclosure, using the enclosure keyhole slots.
- Use 1/4in or 3/8in hardware to floor-mount larger enclosures, using the bottom mounting holes.
- Standard pre-fab conduit knockouts are provided on the side of the enclosure. However, the top or bottom surfaces of the unit can also be used if required. The enclosure should be field-modified as needed.

USER ELECTRICAL CONNECTIONS

- Power wiring connected to the Best Battery Selector user terminals must be rated for the *full* dc load current.
- Refer to the System Schematic on Sheet 1 of 2.
- Connect the positive (+) terminal(s) of the *first* charger/battery set to **TB1** of the Best Battery Selector.
- Connect the positive (+) terminal(s) of the *second* charger/battery set to **TB2** of the Best Battery Selector.
- Connect the positive (+) *common* dc load connection to **TB3** of the Best Battery Selector.
- Connect the negative (-) terminals of the chargers, battery, and dc load(s) together to a common bus, *external* to the Best Battery Selector.

NOTICE Negative (-) dc bus connections *may* pass "through" the Best Battery Selector enclosure if required (and possible). Make sure these connections are properly isolated from all positive (+) BBS components. If available, use external dc disconnects within this circuit.

- If metering and alarm options are installed, a small 2-position terminal block (**TB5+/-**) is supplied for a user negative (-) connection of less than 2 Adc. This voltage sense connection typically accepts ring or spade lugs for no more than #14 AWG wire. The positive (+) dc connection for such metering and alarm options is taken internally from the BBS common dc load output.
- Properly labeled chassis *and* door **ground** connections are also supplied with ZPS stud hardware.

SITE TESTING

- Make sure Best Battery Selector is properly installed along the dc bus. See schematic on Page 1 of 2.
- Place CHARGER #1 (on battery #1) into *Equalize* mode. Leave CHARGER #2 in Float mode.
- Current should *only* flow from charger/battery pairing #1 into BBS TB1(+).
- Voltage on charger/battery pairing #2 should not rise to CHARGER #1's equalize voltage.
- Return CHARGER #1 to Float mode. Place CHARGER #2 (on battery #2) into *Equalize* mode.
- Current should *only* flow from charger/battery pairing #2 into BBS TB2(+).
- Voltage on charger/battery pairing #1 should not rise to CHARGER #2's equalize voltage.
- Return CHARGER #2 to Float mode.

OPTIONS

- The Best Battery Selector can also be equipped with dc meters, alarm relays, alarm indicators lamps, and other options to monitor the dc load voltage and current.
- The dc rating for the Best Battery Selector (without options) is a *maximum* voltage. If voltage-based options are added, the number and type of battery cells used must be supplied to manufacturer before shipment.
- Available Options and Alarms:

• ANALOG DC LOAD VOLTMETER	M10
• ANALOG DC LOAD AMMETER	M11
• DC LOAD DISCONNECT CIRCUIT BREAKER	CB3
• DIODE OPEN ALARM FORM-C CONTACTS	EJ5239 (http://www.atseries.net/PDFs/EJ5239-00.pdf)
• DIODE FAILURE INDICATOR LIGHTS	EJ5239
• HIGH / LOW DC VOLTAGE ALARM W/IND	EJ0083
• END OF DISCHARGE ALARM W/IND	EJ0143
• EOD ALARM W/IND & DISCONNECT	EJ0143

- If any of the above options are installed in the Best Battery Selector, a customized documentation/drawing package will be supplied, along with this standard instruction sheet, defining such options.