

NOTE 2

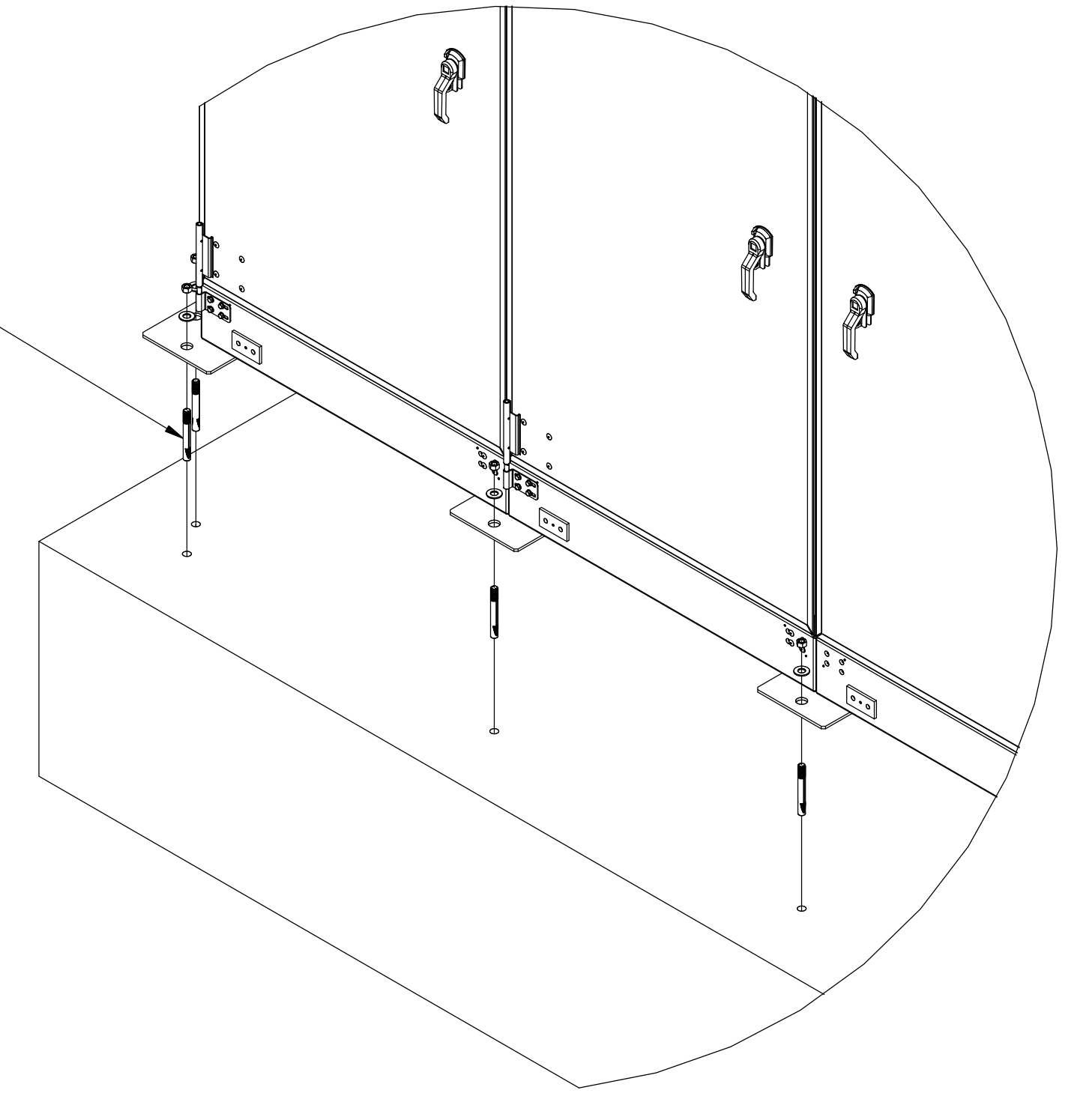

A-A  
MOUNTING DIMENSIONS

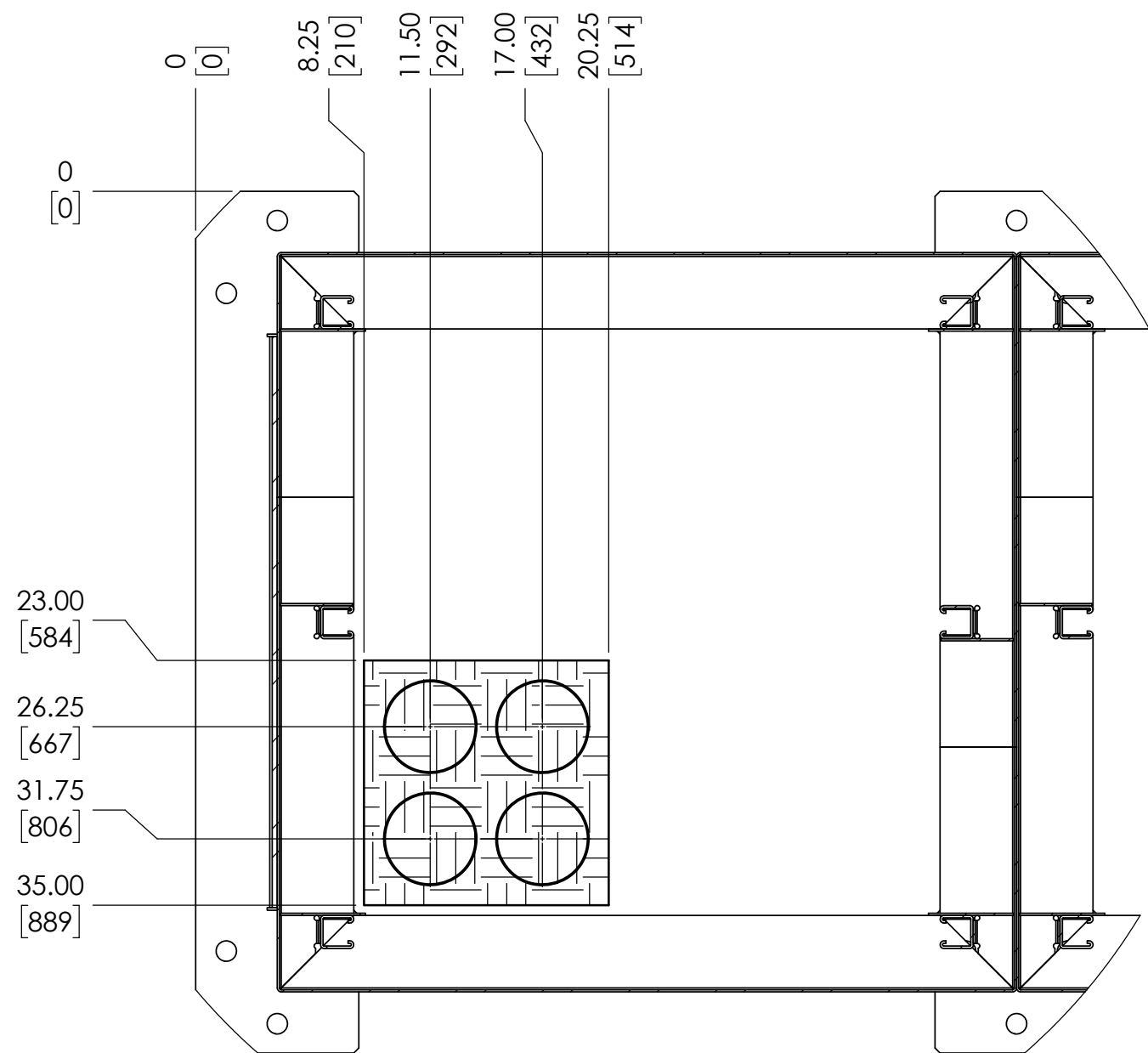
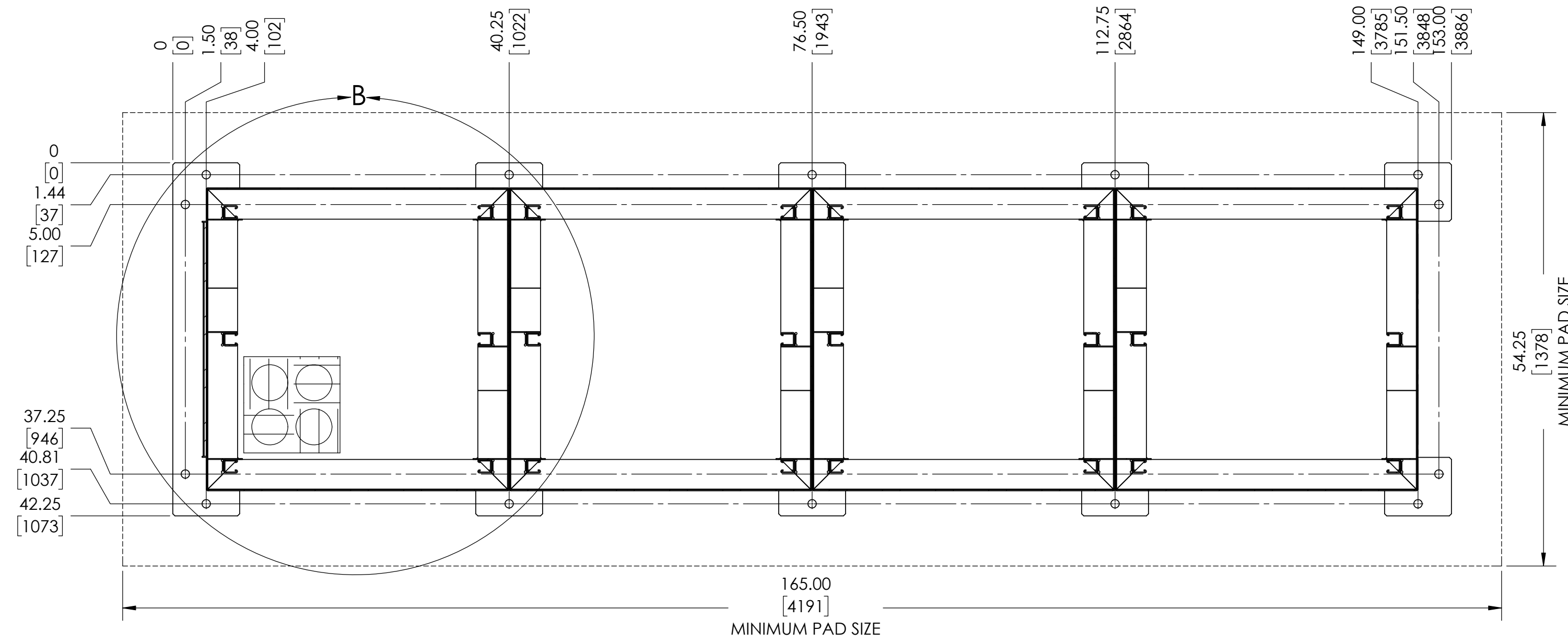

STUB-UP LOCATIONS  
DETAIL B  
SCALE 1 : 8

NOTES:

1. MOUNTING DIMENSIONS SHOWN ON DRAWING ARE FINAL. WE RECOMMEND PLACING CONSOLE THEN DRILLING FOR MOUNTING ANCHORS.
2. ANCHOR BOLTS ARE TO BE HILTI M12 HDA-TR STAINLESS STEEL UNDERCUT (OR EQUIVALENT). HOLE DEPTH TO BE MINIMUM OF 5.3" [135mm], PAD DEPTH TO BE MINIMUM OF 8.0" [203mm]
3. CONCRETE PAD TO EXTEND A MINIMUM OF 6" [153mm] FROM EDGE OF CABINET ON ALL SIDES. SEE MOUNTING DIMENSIONS BELOW. THE WEIGHT OF THE CONSOLE WITH BATTERIES (SPECIFIED IN PURCHASE ORDER) IS 2969lb [1347kg]
4. CONCRETE PAD TO BE 4000 psi OR GREATER.
5. ELECTRICAL CONDUIT MAY ENTER FROM UNDERNEATH CABINET, BUT ONLY THROUGH STUB-UP LOCATIONS SHOWN IN DETAIL B.
6. CONDUIT ENTRY PROVIDED THROUGH SIDE PANEL 10.5in BY 14in GLAND PLATE AVAILABLE FOR KNOCKOUT. KNOCKOUTS MAY NOT BE VISIBLE, USE DIMENSIONS TO VERIFY BREAKAWAY POINTS.

C:\Hindle Vault\Custom Drawings\CONSOLES 2.1\2.1.4 SEC

<small>UNLESS OTHERWISE SPECIFIED ALL DIMENSIONS FOLLOW THE ANG SYSTEMS (INCHES FRACTIONS &amp; DECIMALS) TOLERANCES ARE FRACTIONAL SEE NOTE 10.1.1.1</small>		
	<b>EPIC SERIES 2.0 CONSOLE FOUNDATION DRAWINGS</b> SALES ORDER No. N/A	
<small>PROPERTY AND CONFIDENTIAL NOTICE ANY REPRODUCTION, PARTIAL OR AS A WHOLE OF THIS DOCUMENT WITHOUT THE WRITTEN PERMISSION OF HINDLE POWER IS STRICTLY PROHIBITED</small>	<small>TITLE</small> EPIC SERIES 2.0 CONSOLE FOUNDATION DRAWINGS SALES ORDER No. N/A	<small>SCALE</small> 1:12
<small>REV. SHEET</small> A 3 OF 3	<small>REV</small> A	<small>DWG No</small> <b>JE5276-04</b>

REV.	DATE	DESCRIPTION	DWN BY	CHK BY	APP BY
A	6/10/2020	STANDARD DRAWINGS	KJB	ND	ND
REVISIONS					