

- DESIGN NOTES:
- ENCLOSURE IS A NEMA-3R TYPE CABINET WITH GASKETING AND FOAM INJECTED PANELING. FINISH IS ANSTI 61 GREY POWDERCOAT.
 - HINGES MADE OF STAINLESS STEEL GRADE 316
 - CONDUIT ENTRY PROVIDED THROUGH SIDE PANEL 10.5in BY 14in GLAND PLATE AVAILABLE FOR KNOCKOUT. SEE FOUNDATION DRAWINGS (JE5276-04) FOR KNOCKOUT LOCATIONS. CONDUIT ACCESS ALSO AVAILABLE FROM UNDERNEATH CABINET.
 - LOCATE UNIT ONTO A PERMANENT, FLAT, AND LEVELED SURFACE, PREFERABLY CONCRETE OR OTHER FIREPROOF MATERIAL. SURFACE MUST BE CAPABLE OF SUPPORTING WEIGHT OF COMPLETE SYSTEM AND INSTALLED COMPONENTS. SEE FOUNDATION DRAWING (JE5276-04) FOR LOADING INFORMATION.
 - VENTILATION AND THERMAL MANAGEMENT OF BATTERIES PER IEEE 1635. SEISMIC CERTIFICATION PER IEEE 693.
 - THE WEIGHT OF THE CONSOLE WITHOUT BATTERIES IS 1575lb (714kg)
 - FOR LIFTING, USE OPTIONAL STRAPPING SYSTEM (SEE EI5196-02).

UNLESS OTHERWISE SPECIFIED ALL DIMENSIONS FOLLOW THE AND SYSTEMS INCHES FRACTIONS AND DECIMALS TOLERANCES ARE FRACTIONAL INCHES UNLESS OTHERWISE SPECIFIED

PROPERTY AND CONFIDENTIAL NOTICE ANY REPRODUCTION, PARTIAL OR AS A WHOLE OF THIS DOCUMENT WITHOUT THE WRITTEN PERMISSION OF HINDLEPOWER IS STRICTLY PROHIBITED

TITLE: EPIC SERIES 2.0 CONSOLE
OUTLINE: NEMA 3R STYLE 5063 ENCL
SALES ORDER No. N/A

SCALE: 1:12
Dwg No: **JE5269-04**

REV. A 1 OF 3

REV.	DATE	DESCRIPTION	DWN BY	CHK BY	APP BY
A	6/10/2020	STANDARD DRAWINGS	KJB	ND	ND
REVISIONS					

C:\Hindle Vault\Custom Drawings\CONSOLES 2.1\2.1.4 SEC

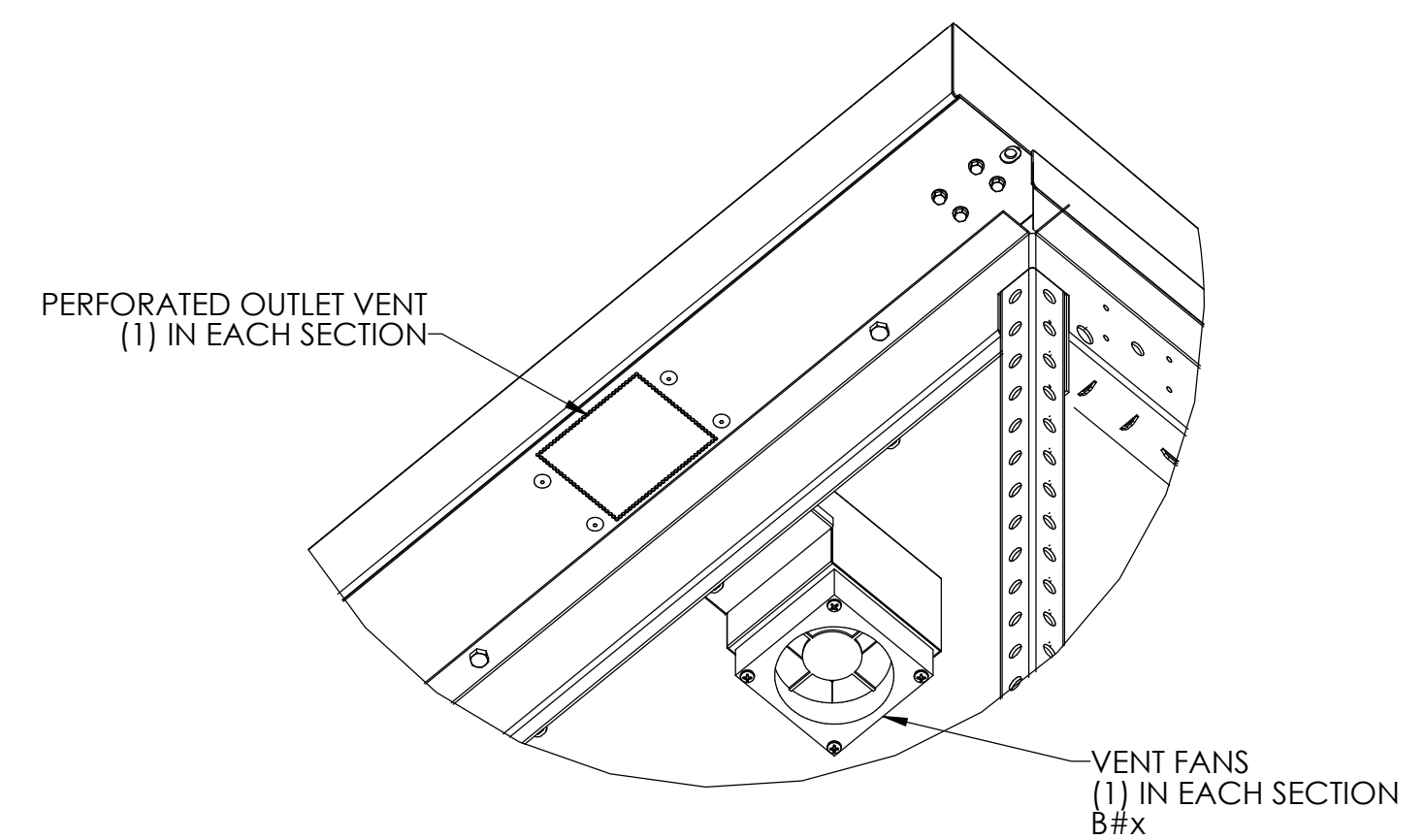
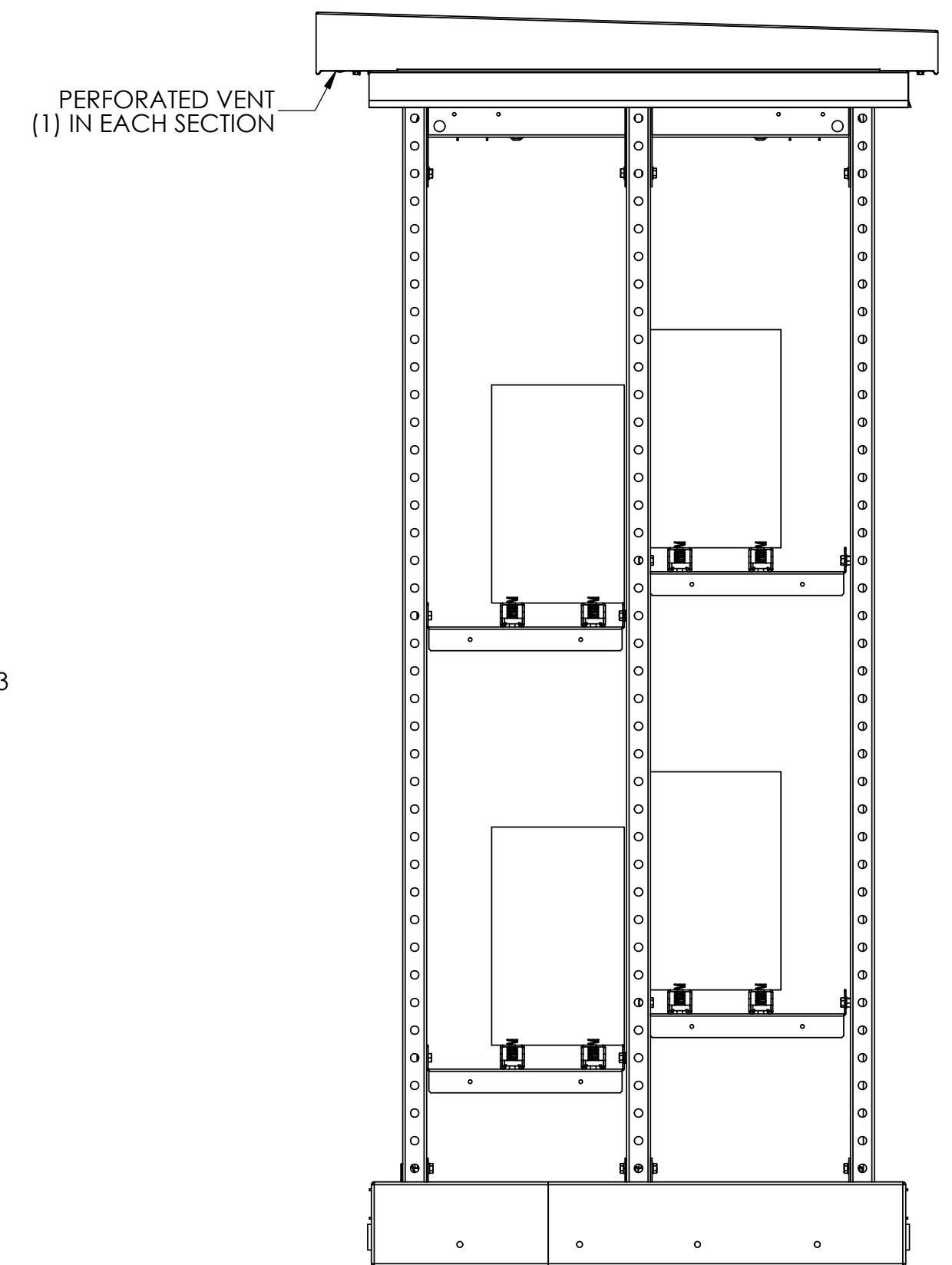
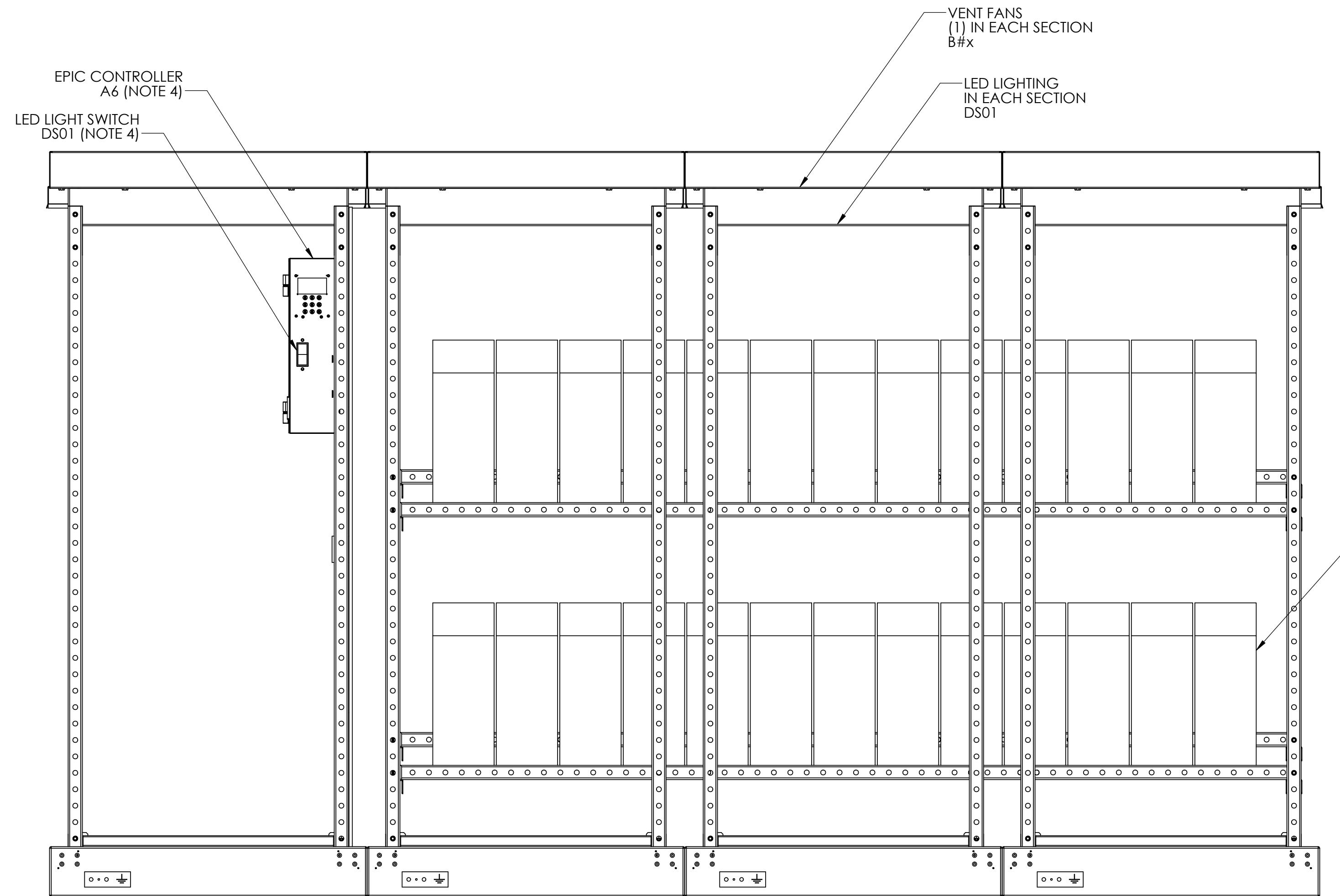
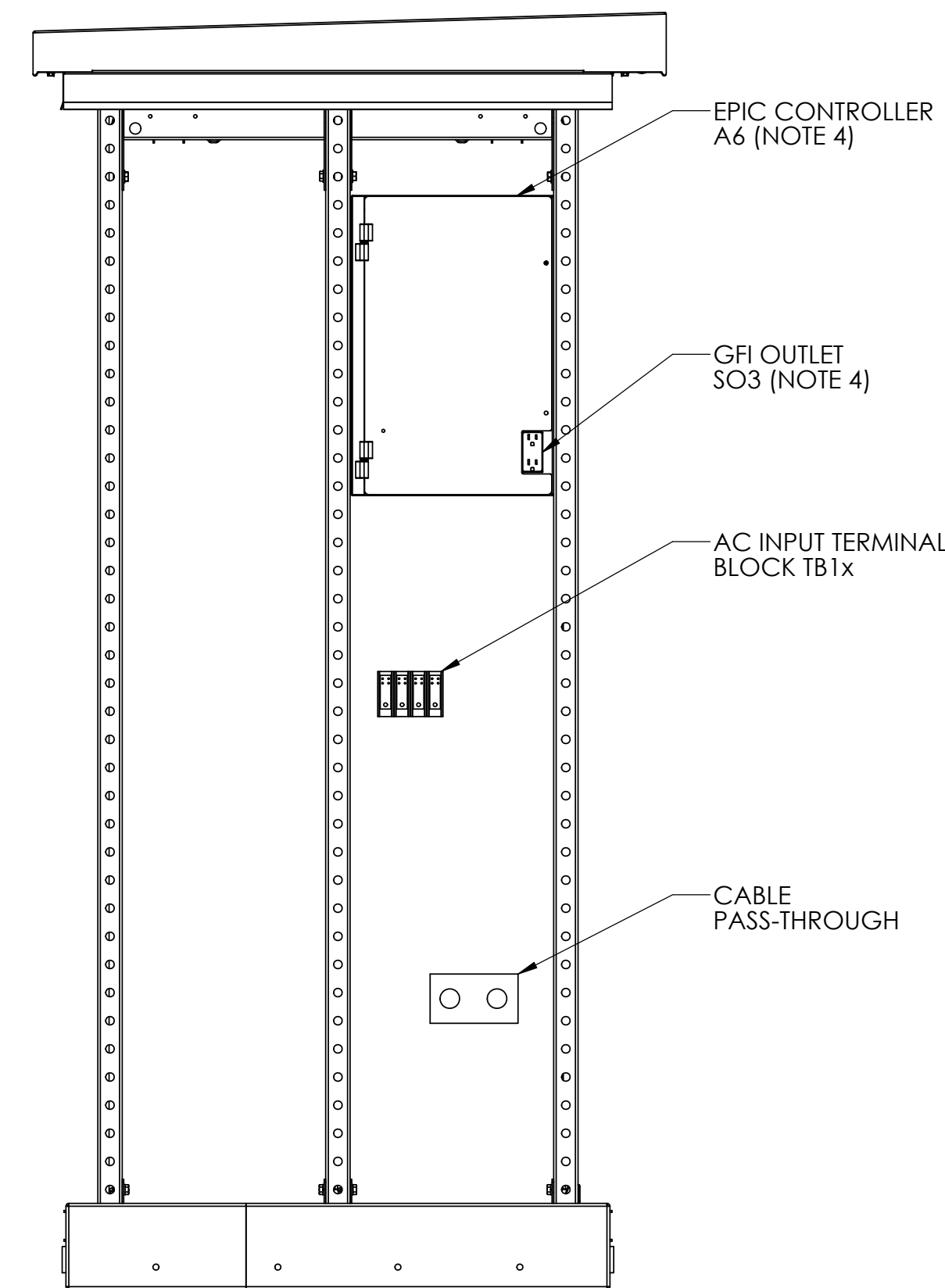

1. TO PROVIDE A CLEAR VIEW OF THE CONSOLE INTERNAL COMPONENTS, THE FOLLOWING ITEMS ARE NOT SHOWN:
 - FRONT DOORS W/ EYE WASH
 - REAR PANELS/DOORS
 - LEFT AND RIGHT SIDE PANELS
2. DO NOT LIFT, PUSH OR RELOCATE THE EPIC CONSOLE WITH BATTERIES INSTALLED WITHIN ENCLOSURE.
3. BATTERY TYPE: REFERENCE (## JARS)
4. EPIC CONTROLLER (A6) CONTAINS
 - A4x RELAY BOARDS
 - A5 DISPLAY BOARD
 - A12 POWER SUPPLY
 - CB# CIRCUIT BREAKERS
 - K2, K3 SOLID STATE RELAYS
 - SO3 GFI OUTLET
 - SW1 LIGHT SWITCH

C:\Hindle Vault\Custom Drawings\CONSOLES 2.12.14 SEC

UNLESS OTHERWISE SPECIFIED ALL DIMENSIONS FOLLOW THE AND SYSTEMS (INCHES-FRACTIONS & DECIMALS) TOLERANCES ARE FRACTIONAL. SEE 14.01.01.01			
PROPERTY AND CONFIDENTIAL NOTICE ANY REPRODUCTION, PARTIAL OR AS A WHOLE OF THIS DOCUMENT WITHOUT THE WRITTEN PERMISSION OF HINDLE POWER IS STRICTLY PROHIBITED.		TITLE EPIC SERIES 2.0 CONSOLE INTERNAL LAYOUT: 1 ELEC. / 3 BATT. SALES ORDER No. N/A	
SCALE: 1:10		REV SHEET JE5270-04 A 2 OF 3	

REV.	DATE	DESCRIPTION	DWN BY	CHK BY	APP BY
A	6/10/2020	STANDARD DRAWINGS	KJB	ND	ND
REVISIONS					

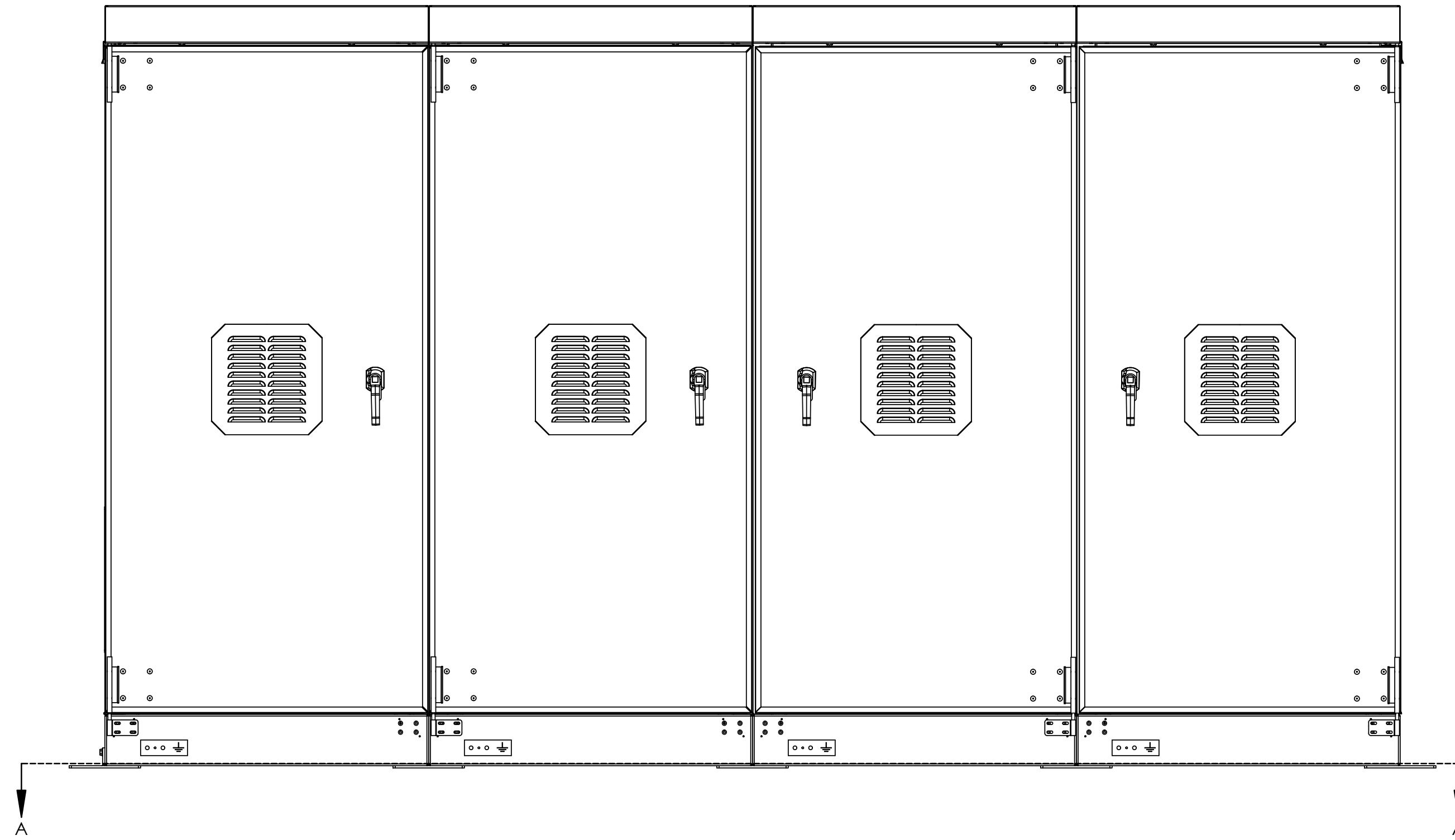
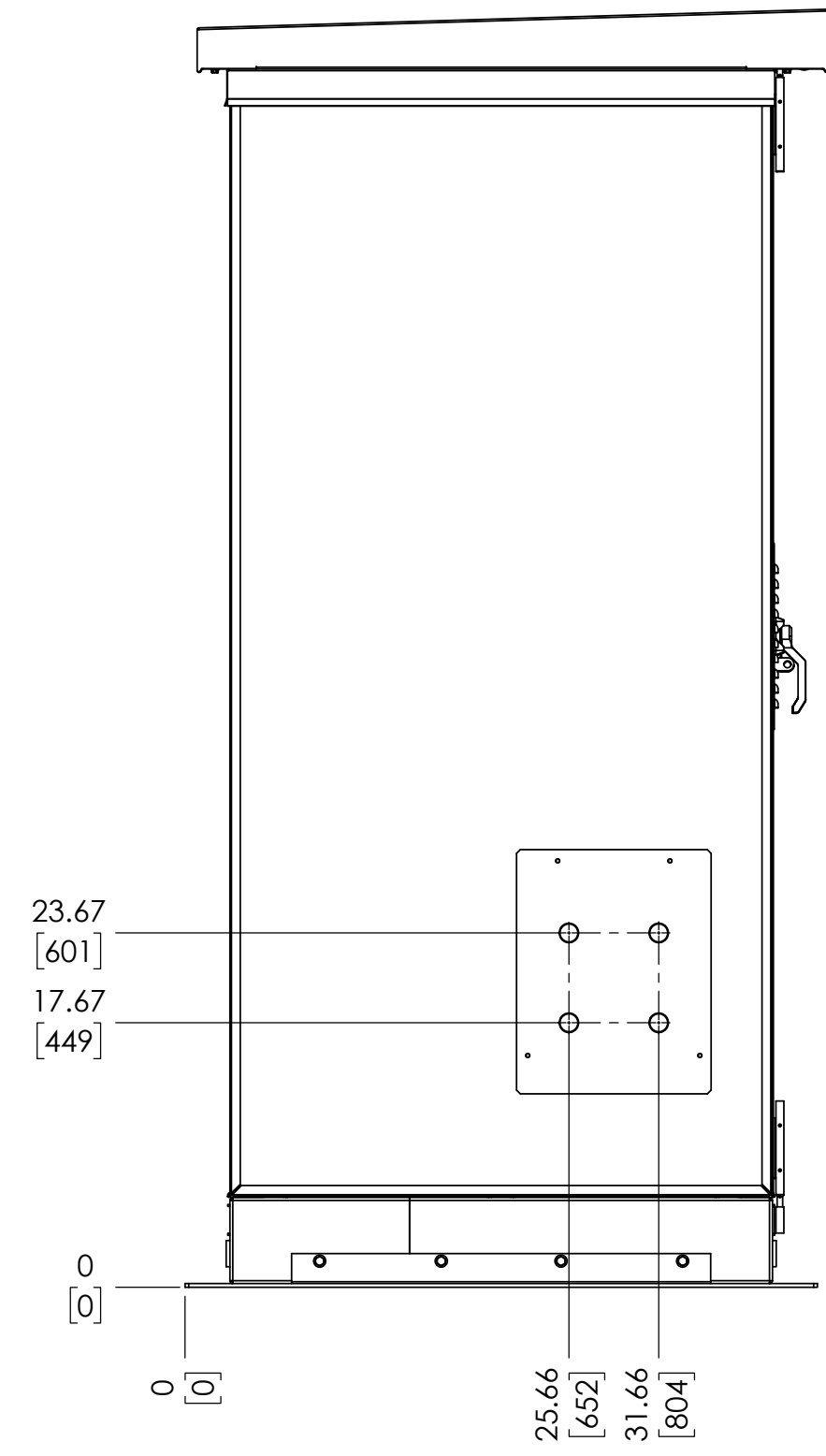

NOTE 2

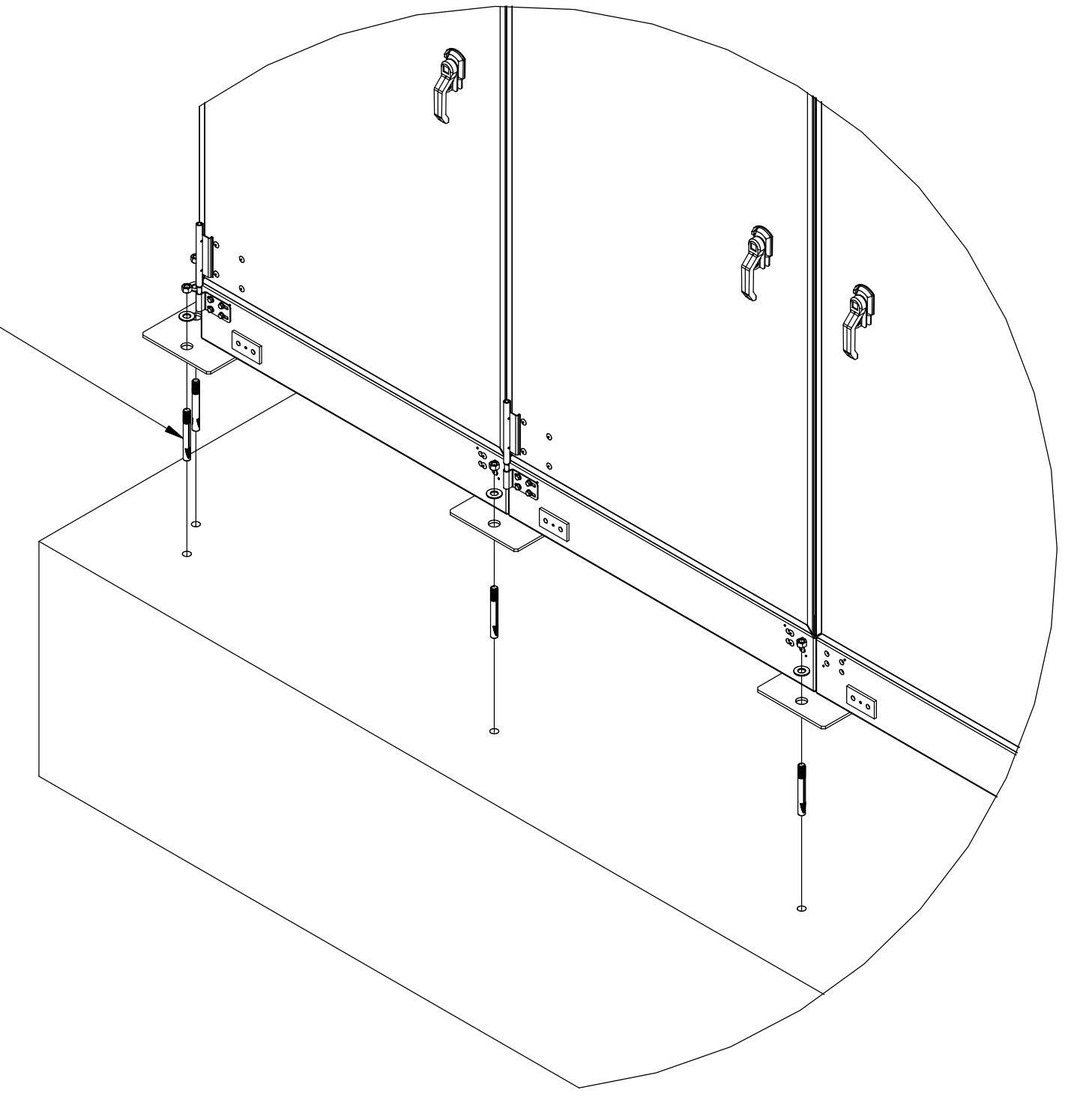

A-A
MOUNTING DIMENSIONS

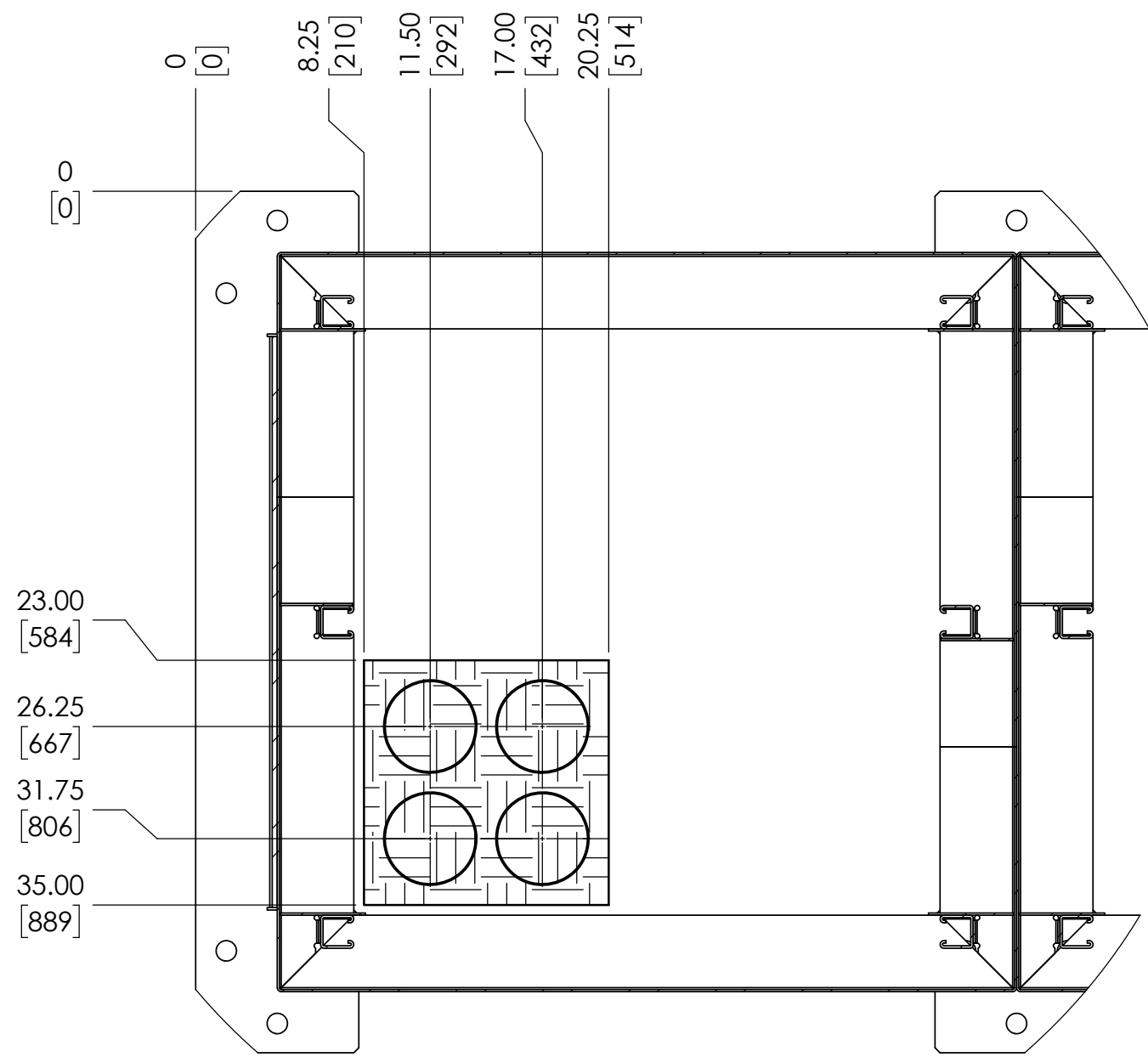
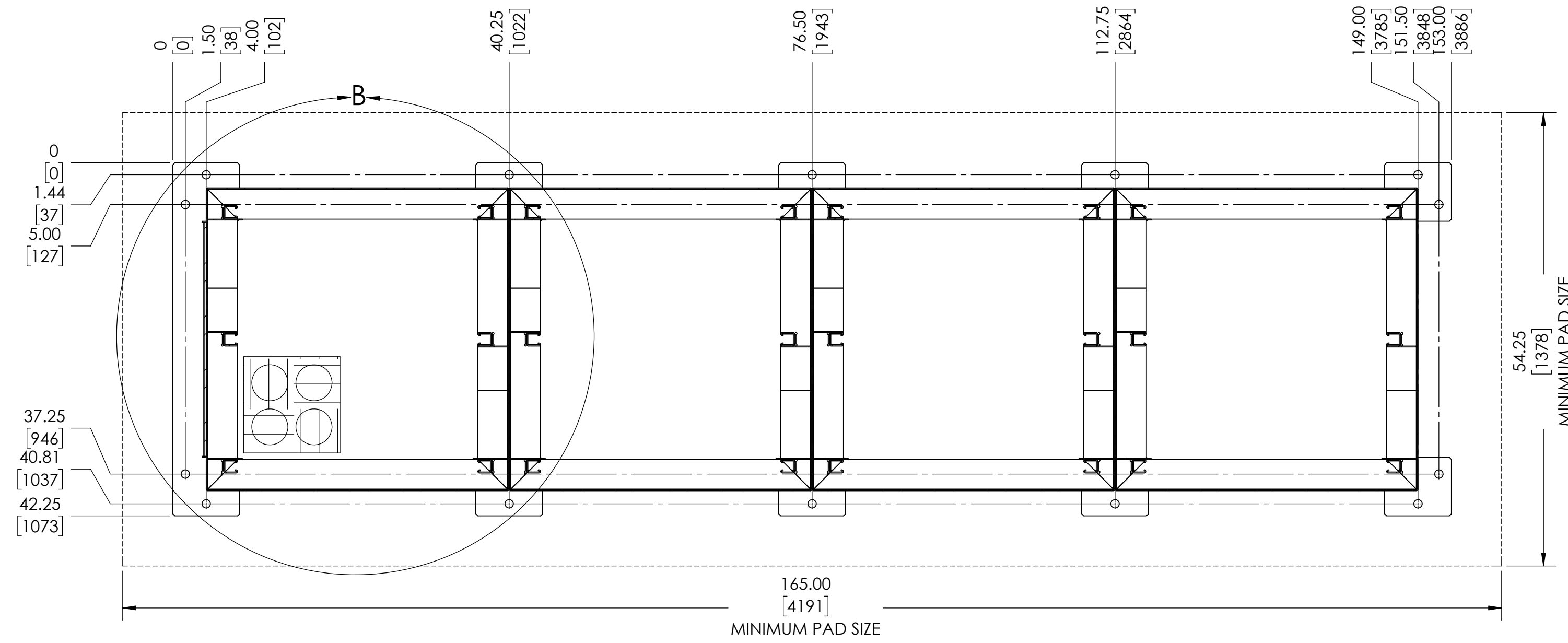

STUB-UP LOCATIONS
DETAIL B
SCALE 1 : 8

NOTES:

1. MOUNTING DIMENSIONS SHOWN ON DRAWING ARE FINAL. WE RECOMMEND PLACING CONSOLE THEN DRILLING FOR MOUNTING ANCHORS.
2. ANCHOR BOLTS ARE TO BE HILTI M12 HDA-TR STAINLESS STEEL UNDERCUT (OR EQUIVALENT). HOLE DEPTH TO BE MINIMUM OF 5.3" [135mm], PAD DEPTH TO BE MINIMUM OF 8.0" [203mm]
3. CONCRETE PAD TO EXTEND A MINIMUM OF 6" [153mm] FROM EDGE OF CABINET ON ALL SIDES. SEE MOUNTING DIMENSIONS BELOW. THE WEIGHT OF THE CONSOLE WITH BATTERIES (SPECIFIED IN PURCHASE ORDER) IS 2969lb [1347kg]
4. CONCRETE PAD TO BE 4000 psi OR GREATER.
5. ELECTRICAL CONDUIT MAY ENTER FROM UNDERNEATH CABINET, BUT ONLY THROUGH STUB-UP LOCATIONS SHOWN IN DETAIL B.
6. CONDUIT ENTRY PROVIDED THROUGH SIDE PANEL 10.5in BY 14in GLAND PLATE AVAILABLE FOR KNOCKOUT. KNOCKOUTS MAY NOT BE VISIBLE, USE DIMENSIONS TO VERIFY BREAKAWAY POINTS.

C:\Hindle Vault\Custom Drawings\CONSOLES 2.1\2.1.4 SEC

<small>UNLESS OTHERWISE SPECIFIED ALL DIMENSIONS FOLLOW THE ANG SYSTEMS (INCHES FRACTIONS & DECIMALS) TOLERANCES ARE FRACTIONAL SEE NOTE #10 & 11</small>	HINDLEPOWER	
	EPIC SERIES 2.0 CONSOLE FOUNDATION DRAWINGS SALES ORDER No. N/A	
<small>PROPERTY AND CONFIDENTIAL NOTICE ANY REPRODUCTION, PARTIAL OR AS A WHOLE OF THIS DOCUMENT WITHOUT THE WRITTEN PERMISSION OF HINDLEPOWER IS STRICTLY PROHIBITED</small>	<small>TITLE</small> EPIC SERIES 2.0 CONSOLE FOUNDATION DRAWINGS SALES ORDER No. N/A	<small>SCALE</small> 1:12
<small>REV. SHEET</small> A 3 OF 3	<small>REV</small> A	<small>DWG No</small> JE5276-04

REV.	DATE	DESCRIPTION	DWN BY	CHK BY	APP BY
A	6/10/2020	STANDARD DRAWINGS	KJB	ND	ND
REVISIONS					

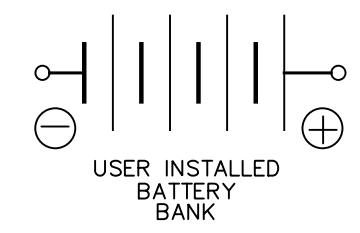
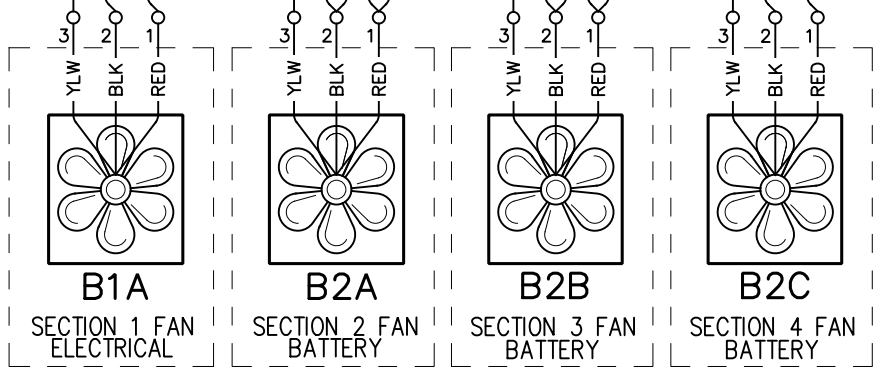
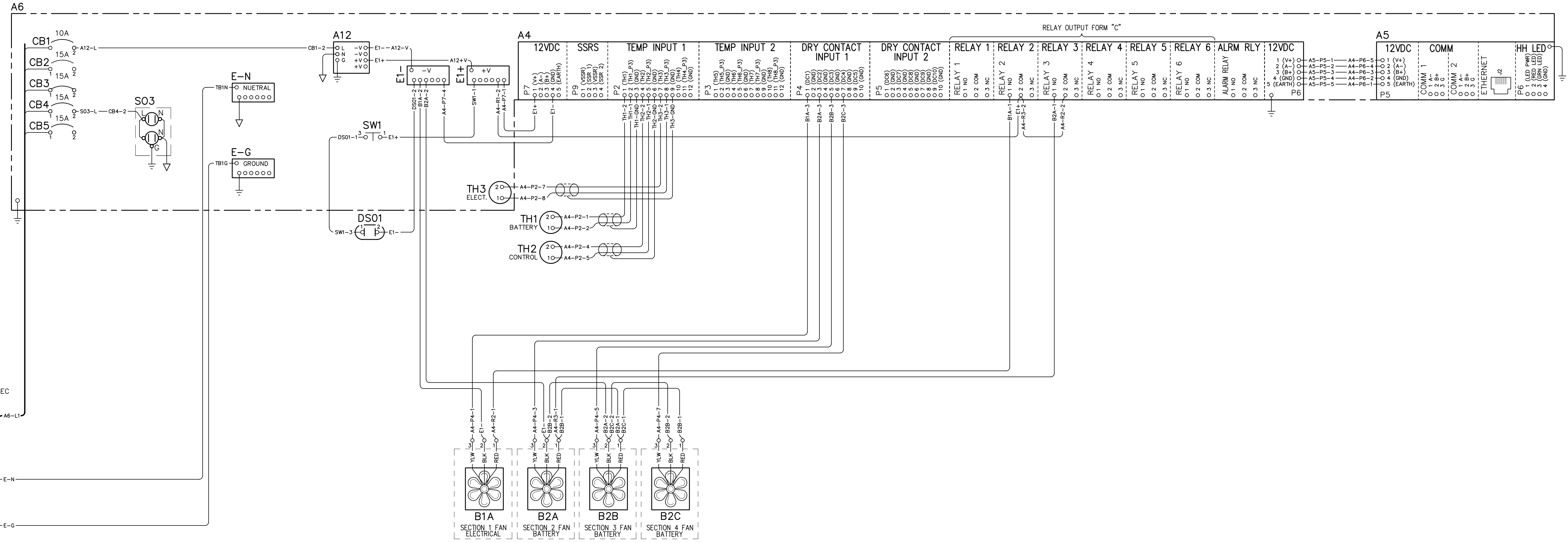
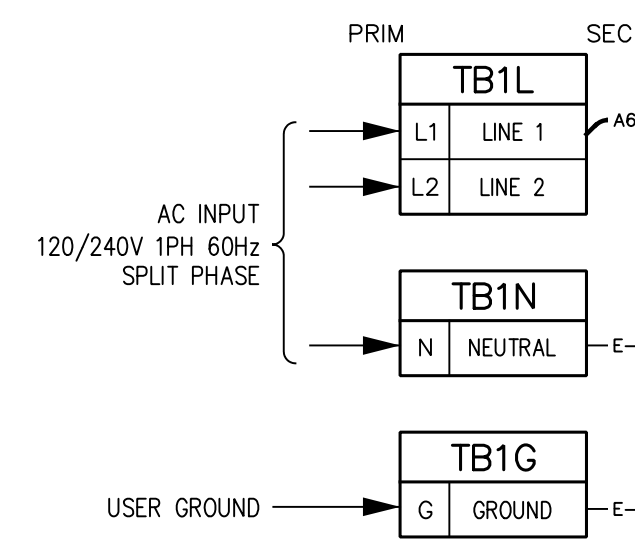

EPIC SERIES COMPONENTS

SYMBOL	DESCRIPTION
A4	HINDLE HEALTH CONTROLLER
A5	HINDLE HEALTH DISPLAY
A6	EPIC CONTROLLER
A12	12VDC POWER SUPPLY
B#X	VENT FANS
CB1	CIRCUIT BREAKER FOR A12 P/S
CB2	CIRCUIT BREAKER FOR HEATING SYSTEM
CB3	CIRCUIT BREAKER FOR AIR CONDITIONER
CB4	CIRCUIT BREAKER FOR GFI OUTLET
DS01	CONSOLE LED LIGHTS
E1X	12VDC CONNECTION POINTS
E-N	GROUND CONNECTION POINTS
E-G	NEUTRAL CONNECTION POINTS
S03	15A GFI OUTLET
SW1	CONSOLE LED LIGHT SWITCH(ES)
TB1X	AC INPUT TERMINAL BLOCK
TH1	BATTERY THERMAL SENSOR
TH2	CONTROL THERMAL SENSOR
TH3	ELECTRONIC SECTION THERMAL SENSOR

LEGEND FOR EPIC LINE

SYMBOL	DESCRIPTION
○	DEVICE TERMINAL
◐	TERMINAL BLOCK POINT IN TRANSFORMER
◑	TERMINAL BLOCK POINT FOR SCADA
◒	TERMINAL BLOCK POINT FOR COMMUNICATIONS
◓	TERMINAL BLOCK POINT IN POWER CIRCUIT BREAKER
▲	TERMINAL IN A.C. OR D.C. PANELBOARD
—▲	SHIPPED WITH WIRING INSTALLED
---	WIRING TO BE INSTALLED

I/O TERMINAL	DESCRIPTION - TYPE	CONNECTION
TB1L,N,G PRIM	LINE 1, LINE 2 AC INPUT / USER NTRL, GND TERMINALS - CU-ALUMINUM COMP LUG	2/0-#14 AWG
TB1L,N,G SEC	LINE 1, LINE 2 AC INPUT / USER NTRL, GND TERMINALS - CU-ALUMINUM COMP LUG	#4-#14 AWG

UNLESS OTHERWISE SPECIFIED ALL DIMENSIONS FOLLOW THE ANSI SYSTEM #1 (INCHES/POUNDS & SECONDS) TOLERANCES ARE: DEC. -0.125; ENG. 0.125	 HINDLEPOWER 1075 Saint John Street Easton, PA 18042-6661 PH 610-330-9000 FAX 610-330-8010 www.hindlepowerinc.com
TITLE: EPIC SERIES 2.0 CONSOLE CONNECTION DIAGRAM: 1 ELEC. SECTION 3 BATT SECTIONS SALES ORDER NO. N/A	
A 7/15/2020 STANDARD DRAWINGS	DRN BY: KJB CHK BY: ND APP BY: ND
SCALE: NTS DWG No: JE5272-04	SHEET: 1 OF 1