

DESIGN NOTES:

- ENCLOSURE IS A NEMA-3R TYPE CABINET WITH GASKETING AND FOAM INJECTED PANELING. FINISH IS ANSTI 61 GREY POWDERCOAT.
- HINGES MADE OF STAINLESS STEEL GRADE 316
- CONDUIT ENTRY PROVIDED THROUGH SIDE PANEL 10.5in BY 14in GLAND PLATE AVAILABLE FOR KNOCKOUT. SEE FOUNDATION DRAWINGS (JE5276-01) FOR KNOCKOUT LOCATIONS. CONDUIT ACCESS ALSO AVAILABLE FROM UNDERNEATH CABINET.
- LOCATE UNIT ONTO A PERMANENT, FLAT, AND LEVELED SURFACE, PREFERABLY CONCRETE OR OTHER FIREPROOF MATERIAL. SURFACE MUST BE CAPABLE OF SUPPORTING WEIGHT OF COMPLETE SYSTEM AND INSTALLED COMPONENTS. SEE FOUNDATION DRAWING (JE5276-01) FOR LOADING INFORMATION.
- VENTILATION AND THERMAL MANAGEMENT OF BATTERIES PER IEEE 1635. SEISMIC CERTIFICATION PER IEEE 693.
- THE WEIGHT OF THE CONSOLE WITHOUT BATTERIES IS 532lb [241kg]
- FOR LIFTING, USE OPTIONAL STRAPPING SYSTEM SEE E15196-01.

C:\Hindle Vault\Custom Drawings\CONSOLES 2.1\2.1.1 SEC

| | | | | | |
|---|-----------|---|--------|---|--------|
| UNLESS OTHERWISE SPECIFIED ALL DIMENSIONS FOLLOW THE AND SYSTEMS (INCHES FRACTIONS & DECIMALS TOLERANCES ARE FRAC: 1/16, DEC: 0.015, ANG: 0.5°) | | HINDLEPOWER | | 1075 South 10th Street Buckeye, PA 15086-0461 PH: 412-281-8800 FAX: 412-281-8805 WWW.HINDLEPOWER.COM | |
| PROPERTY AND CONFIDENTIAL NOTICE ANY REPRODUCTION, PARTIAL OR AS A WHOLE OF THIS DOCUMENT WITHOUT THE WRITTEN PERMISSION OF HINDLEPOWER IS STRICTLY PROHIBITED. | | TITLE EPIC SERIES 2.0 CONSOLE OUTLINE: NEMA 3R STYLE 5063 ENCL SALES ORDER No. N/A | | SCALE: DWGS No. JE5269-01 | |
| REV. | DATE | DESCRIPTION | DWN BY | CHK BY | APP BY |
| A | 6/10/2020 | STANDARD DRAWINGS | KJB | ND | ND |
| REVISIONS | | | | | |
| SCALE: 1:10 | | | SHEET | | 1 OF 3 |

| | | | | | |
|------|-----------|-------------------|--------|--------|--------|
| REV. | DATE | DESCRIPTION | DWN BY | CHK BY | APP BY |
| A | 6/10/2020 | STANDARD DRAWINGS | KJB | ND | ND |

8 7 6 5 4 3 2 1

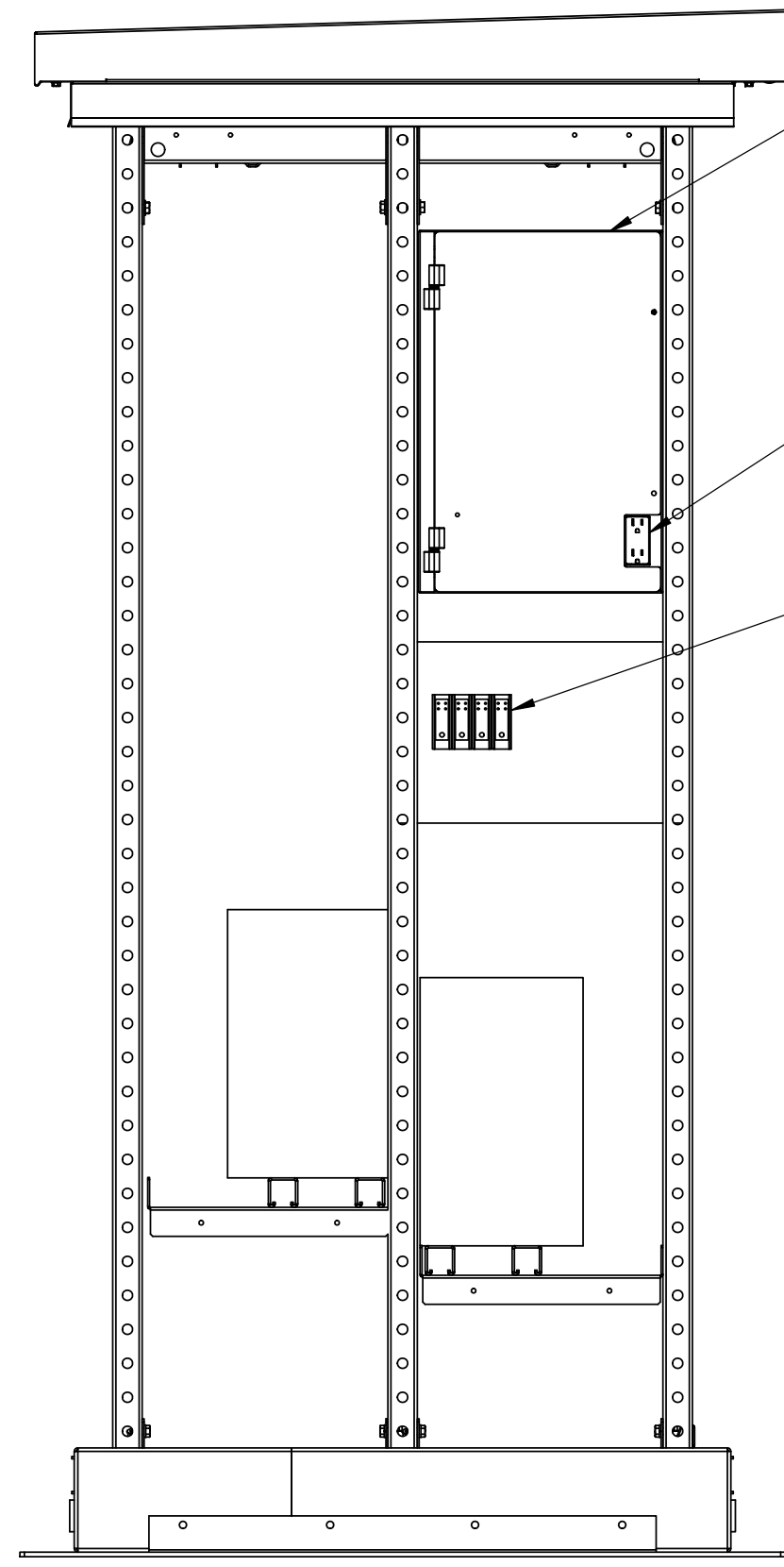

EPIC CONTROLLER
A6 (NOTE 4)

GFI OUTLET
SO3 (NOTE 4)

AC INPUT TERMINAL
BLOCK TB1x

LED LIGHT SWITCH
SW1 (NOTE 4)

EPIC CONTROLLER
A6 (NOTE 4)

AC INPUT TERMINAL
BLOCK TB1x

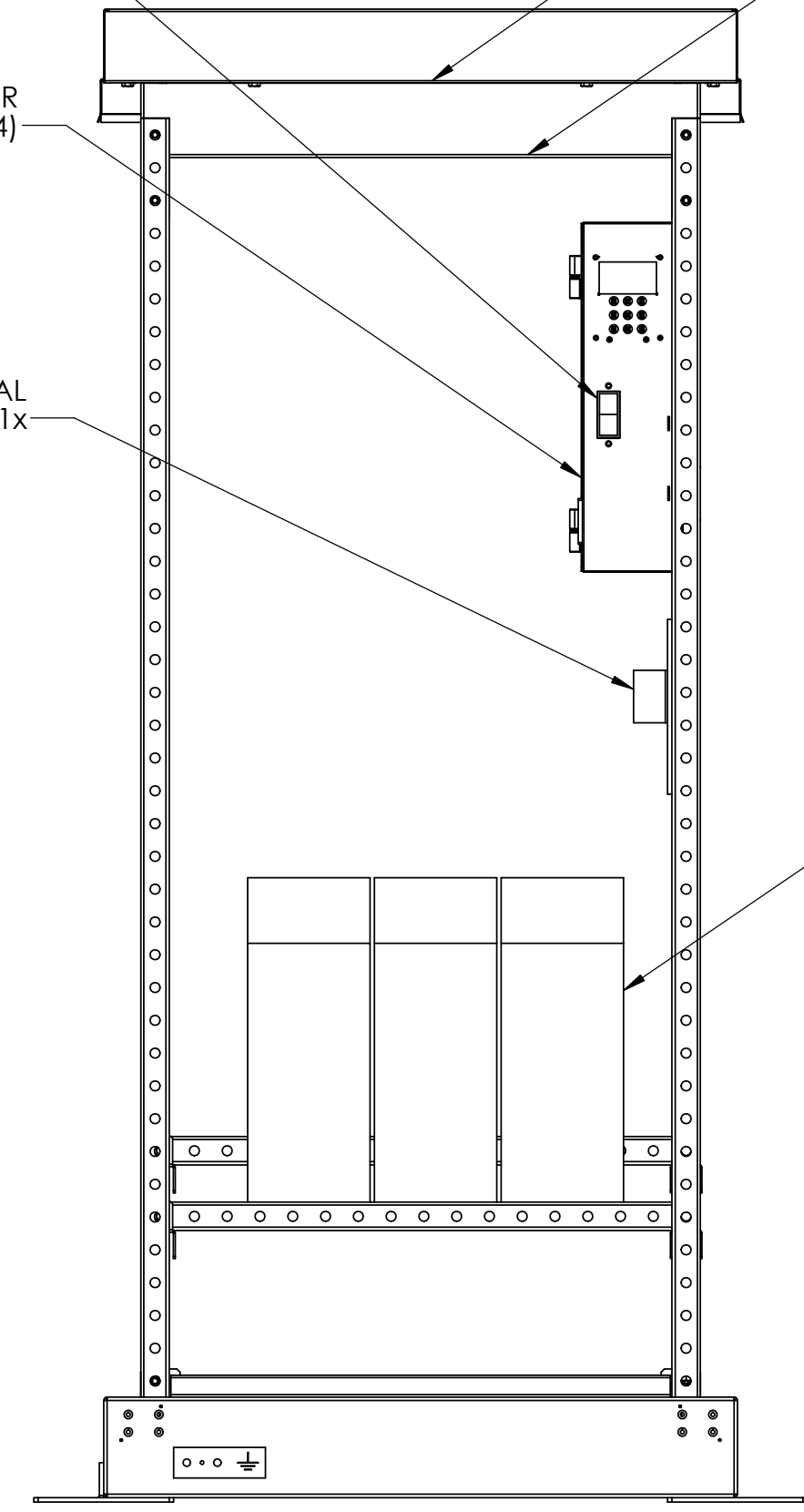

VENT FANS
(2) STACKED IN SECTION
B#x

LED LIGHTING
DS01

NOTE 3

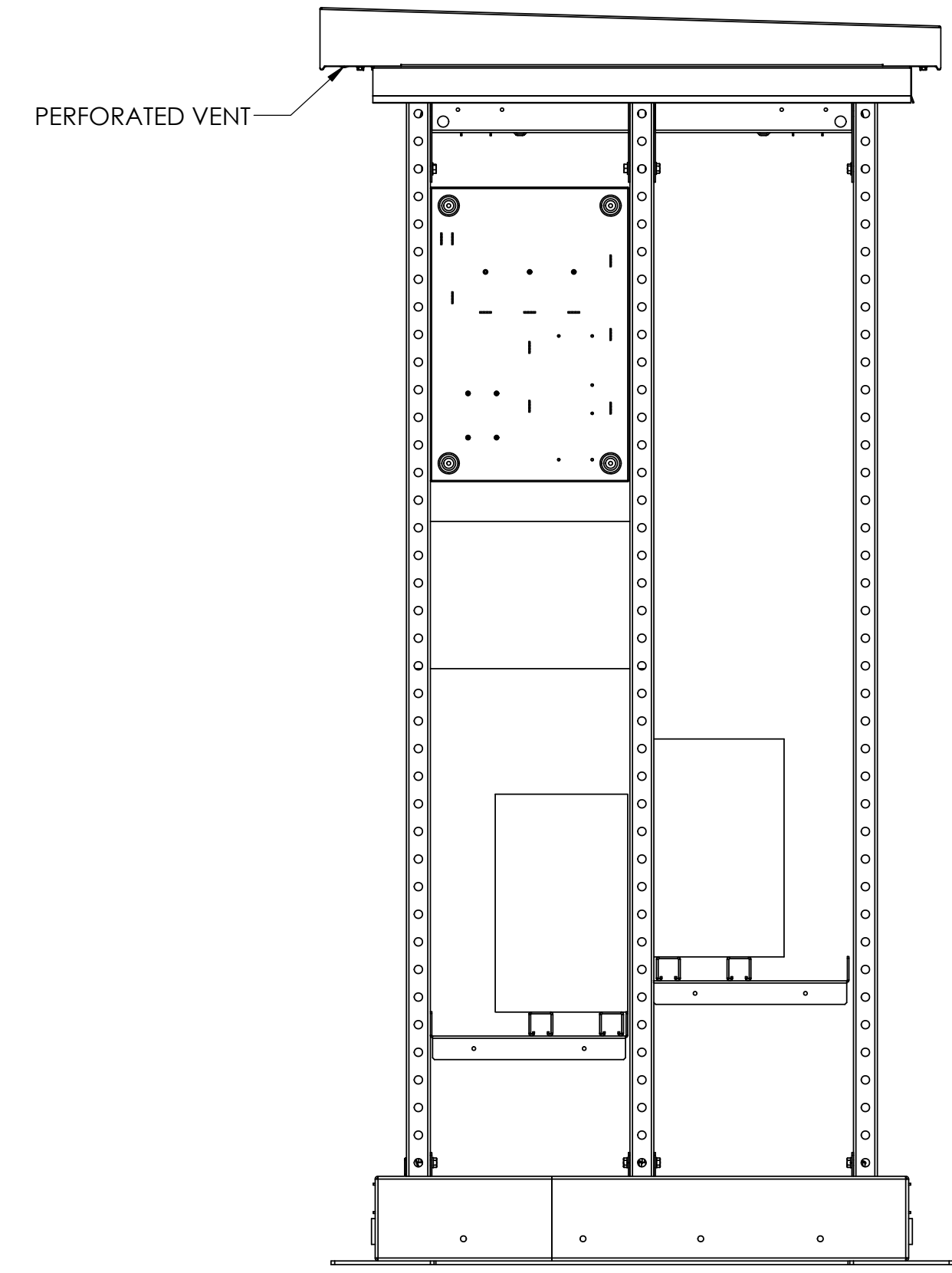

PERFORATED VENT

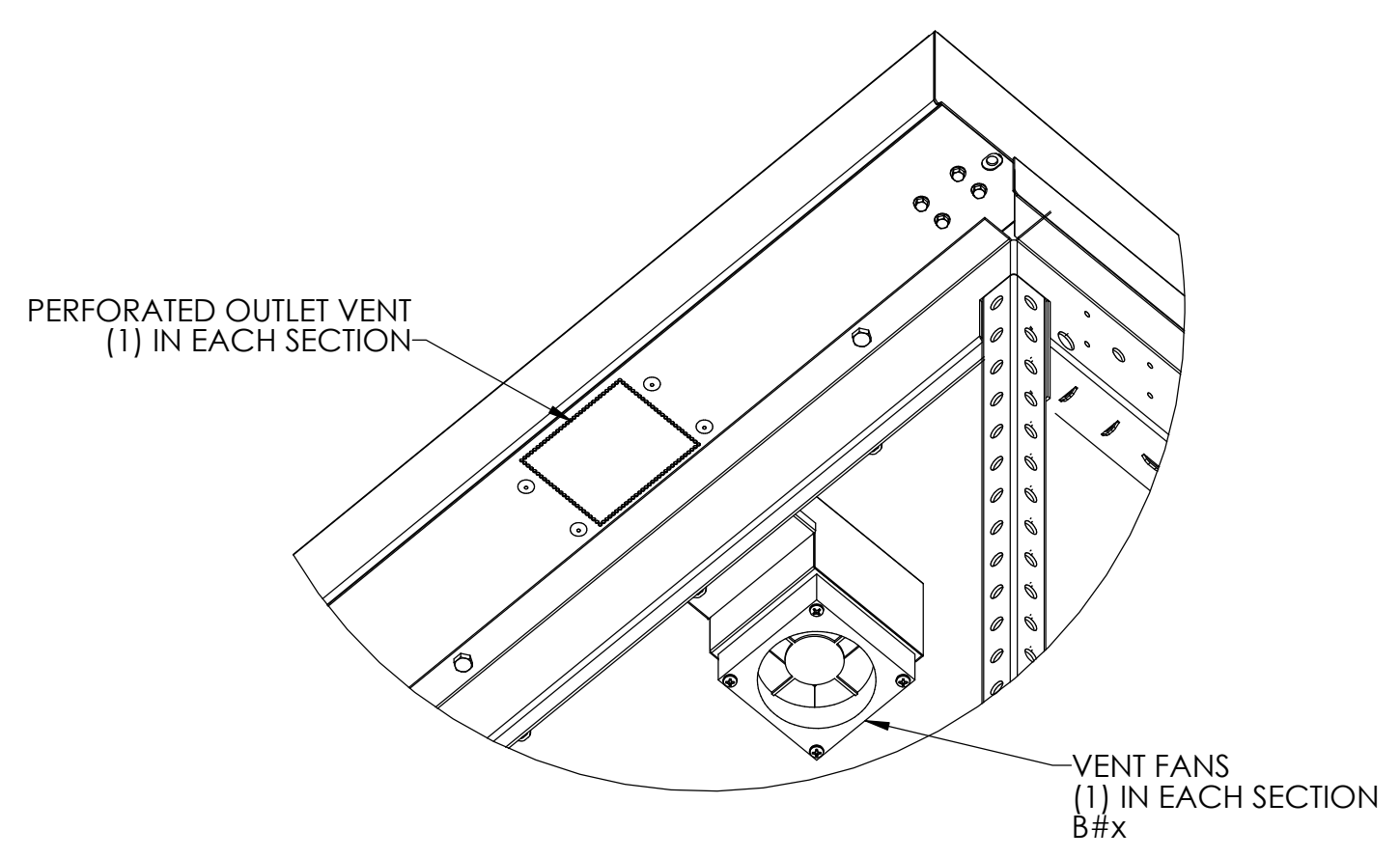

PERFORATED OUTLET VENT
(1) IN EACH SECTION

VENT FANS
(1) IN EACH SECTION
B#x

1. TO PROVIDE A CLEAR VIEW OF THE CONSOLE INTERNAL COMPONENTS, THE FOLLOWING ITEMS ARE NOT SHOWN:
 - FRONT DOORS W/ EYE WASH
 - REAR PANELS/DOORS
 - LEFT AND RIGHT SIDE PANELS
2. DO NOT LIFT, PUSH OR RELOCATE THE EPIC CONSOLE WITH BATTERIES INSTALLED WITHIN ENCLOSURE.
3. BATTERY TYPE: REFERENCE (## JARS)
4. EPIC CONTROLLER (A6) CONTAINS
 - A4x RELAY BOARDS
 - A5 DISPLAY BOARD
 - A12 POWER SUPPLY
 - CB# CIRCUIT BREAKERS
 - K2, K3 SOLID STATE RELAYS
 - SO3 GFI OUTLET
 - SW1 LIGHT SWITCH
 - TB1x AC INPUT TERMINAL BLOCK

C:\Hindle Vault\Custom Drawings\CONSOLES 2.1\2.1.1 SEC

| | | | |
|--|--|---|--|
| UNLESS OTHERWISE SPECIFIED ALL DIMENSIONS FOLLOW THE AND SYSTEMS (INCHES-FRACTIONS & DECIMALS) TOLERANCES ARE FRAC. 1/16" DEC. 1/10" W/ 0.01" | | HINDLEPOWER | |
| PROPERTY AND CONFIDENTIAL NOTICE ANY REPRODUCTION, PARTIAL OR AS A WHOLE OF THIS DOCUMENT WITHOUT THE WRITTEN PERMISSION OF HINDLEPOWER IS STRICTLY PROHIBITED | | TITLE EPIC SERIES 2.0 CONSOLE INTERNAL LAYOUT: 0 ELEC. / 1 BATT. SALES ORDER No. N/A | |
| SCALE: 1:10 | | REV SHEET A 2 OF 3 | |

| REV. | DATE | DESCRIPTION | DWN BY | CHK BY | APP BY |
|-----------|-----------|-------------------|--------|--------|--------|
| A | 6/10/2020 | STANDARD DRAWINGS | KJB | ND | ND |
| REVISIONS | | | | | |

8 7 6 5 4 3 2 1

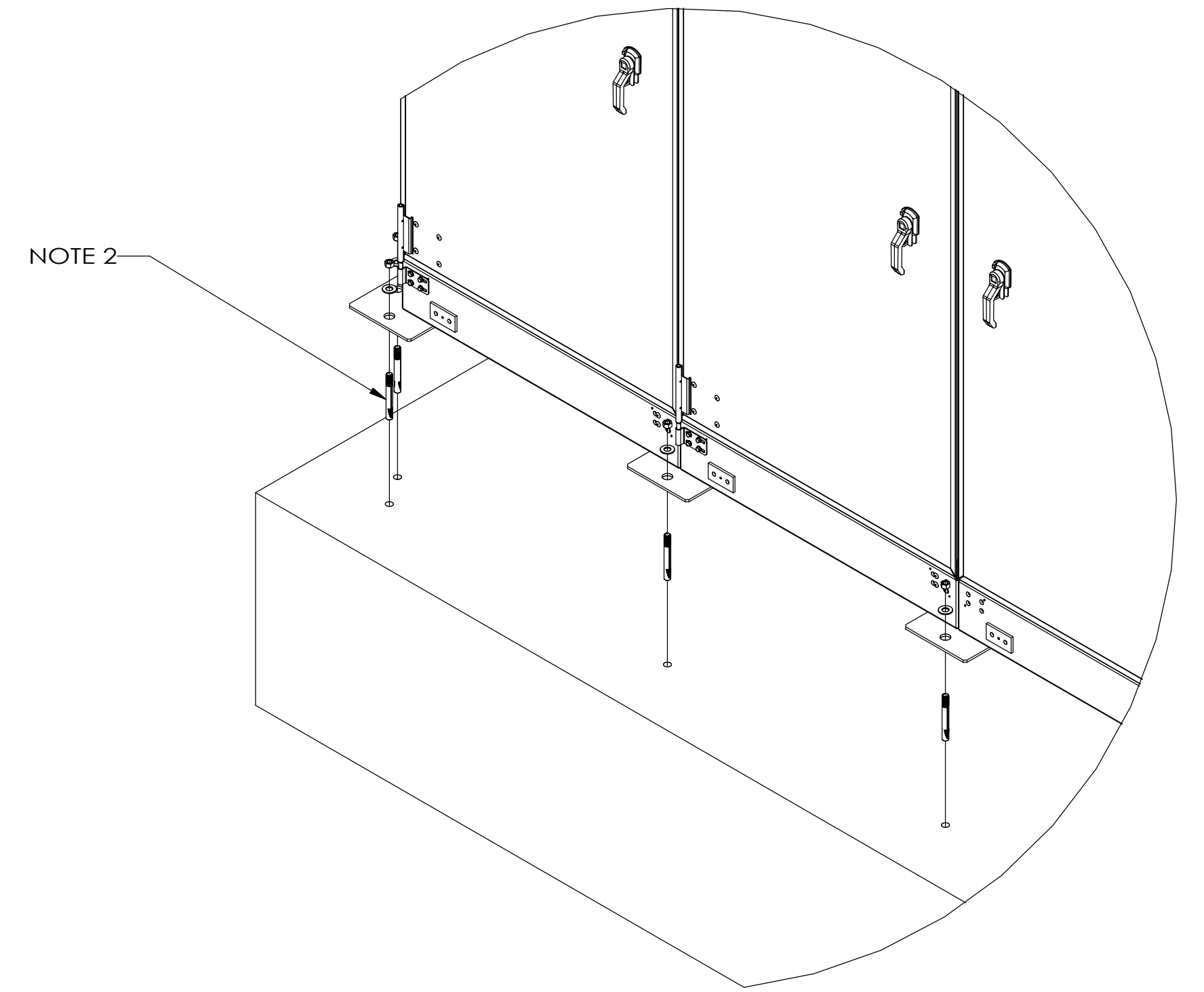
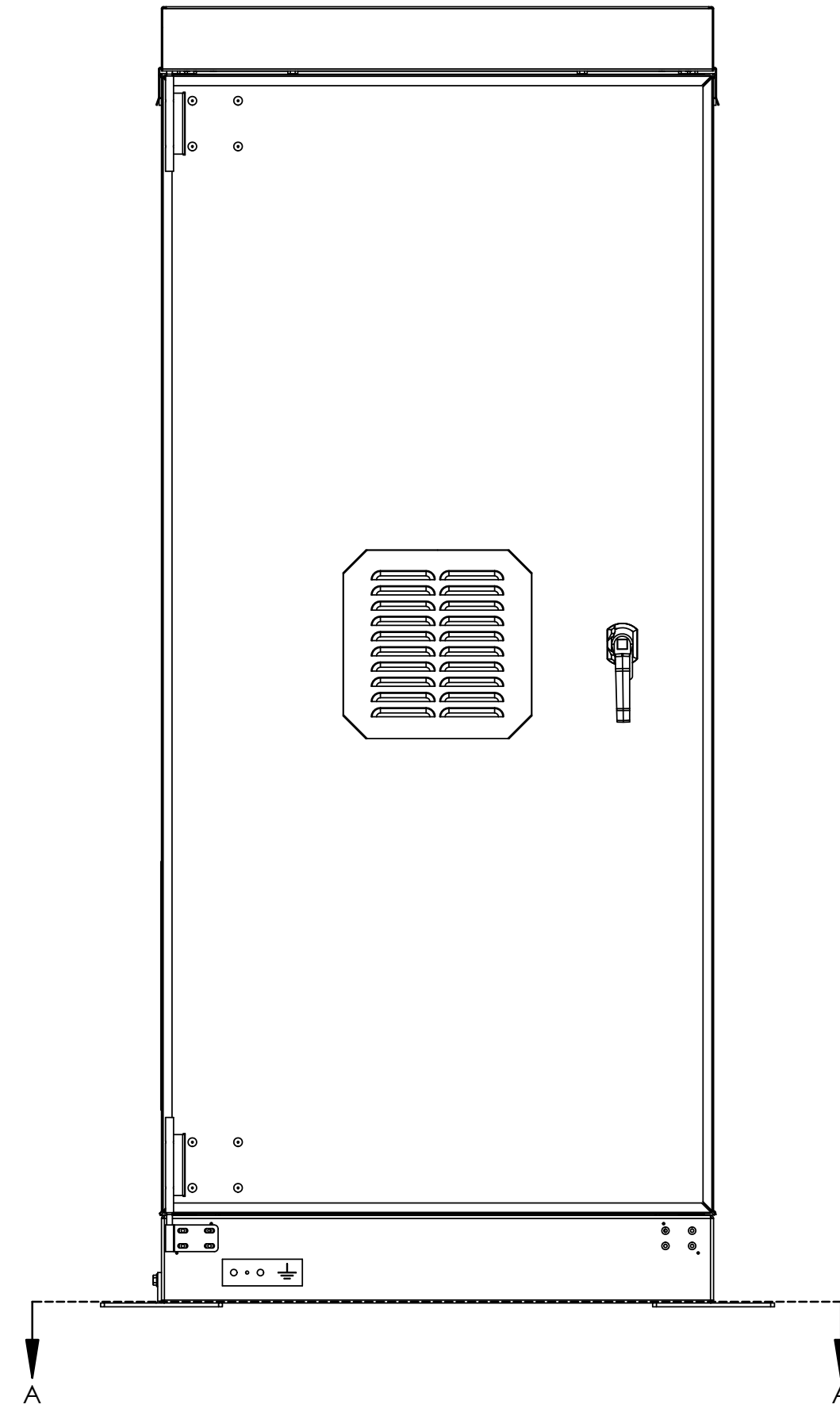
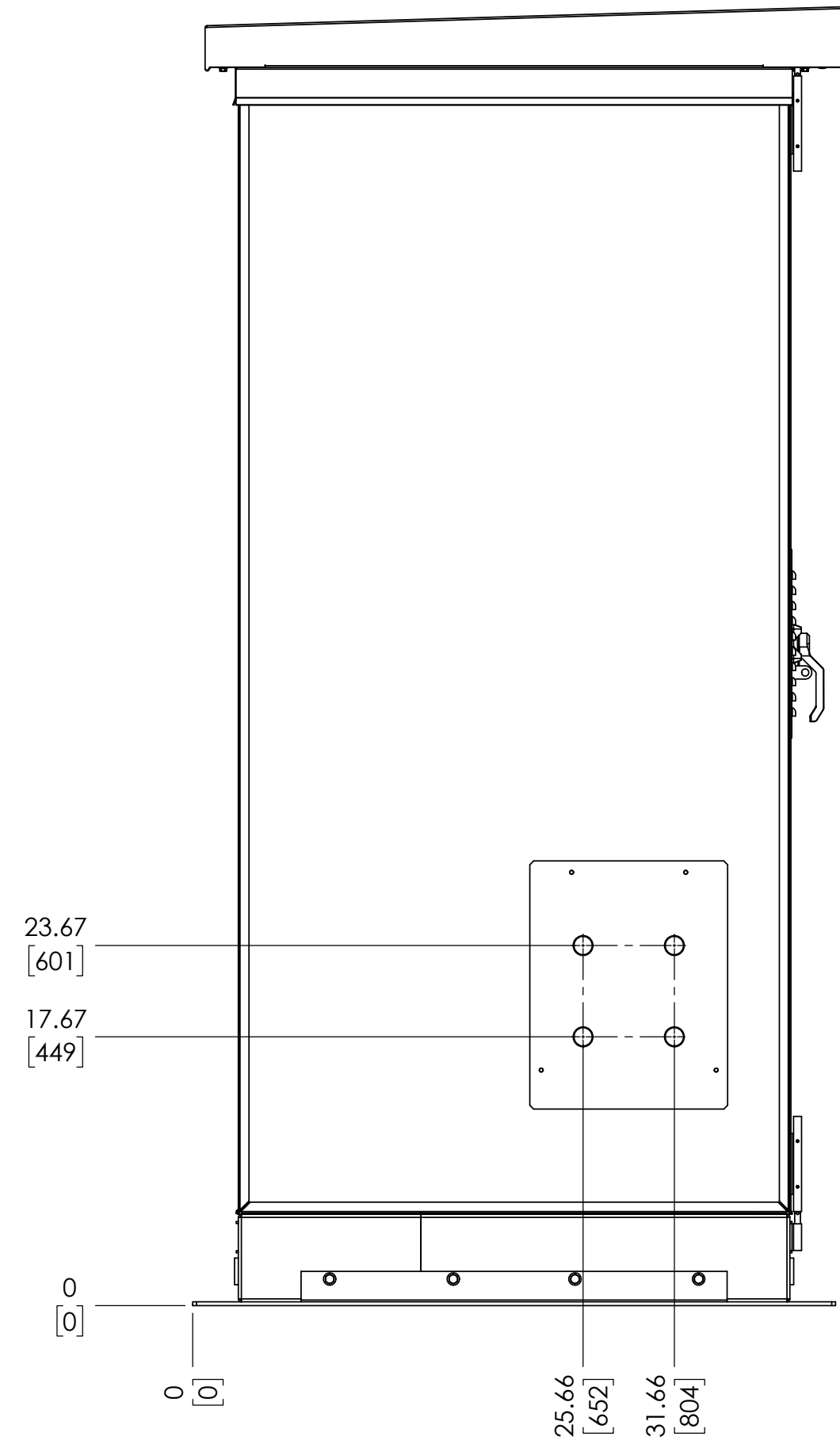

A-A
MOUNTING DIMENSIONS

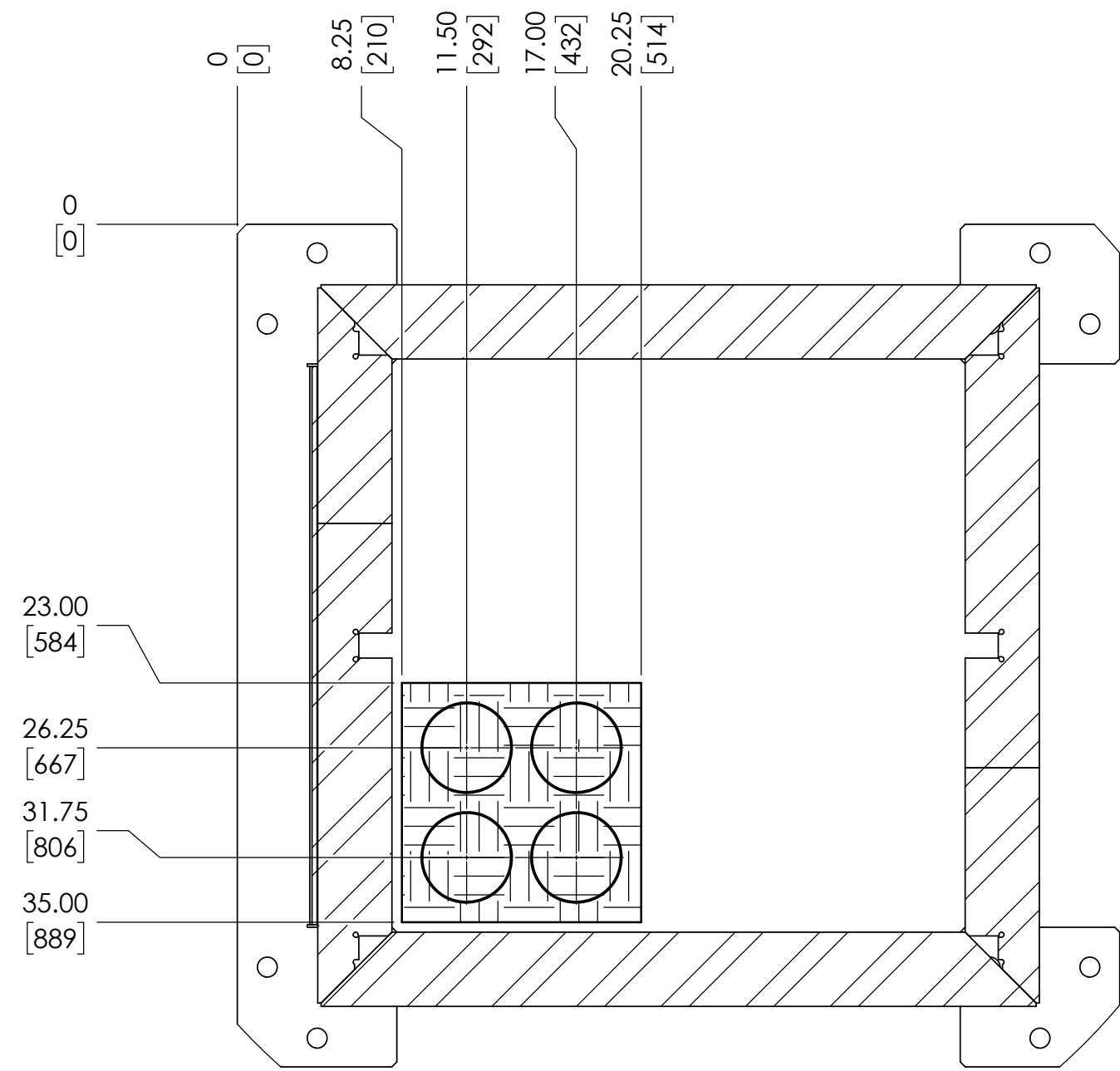
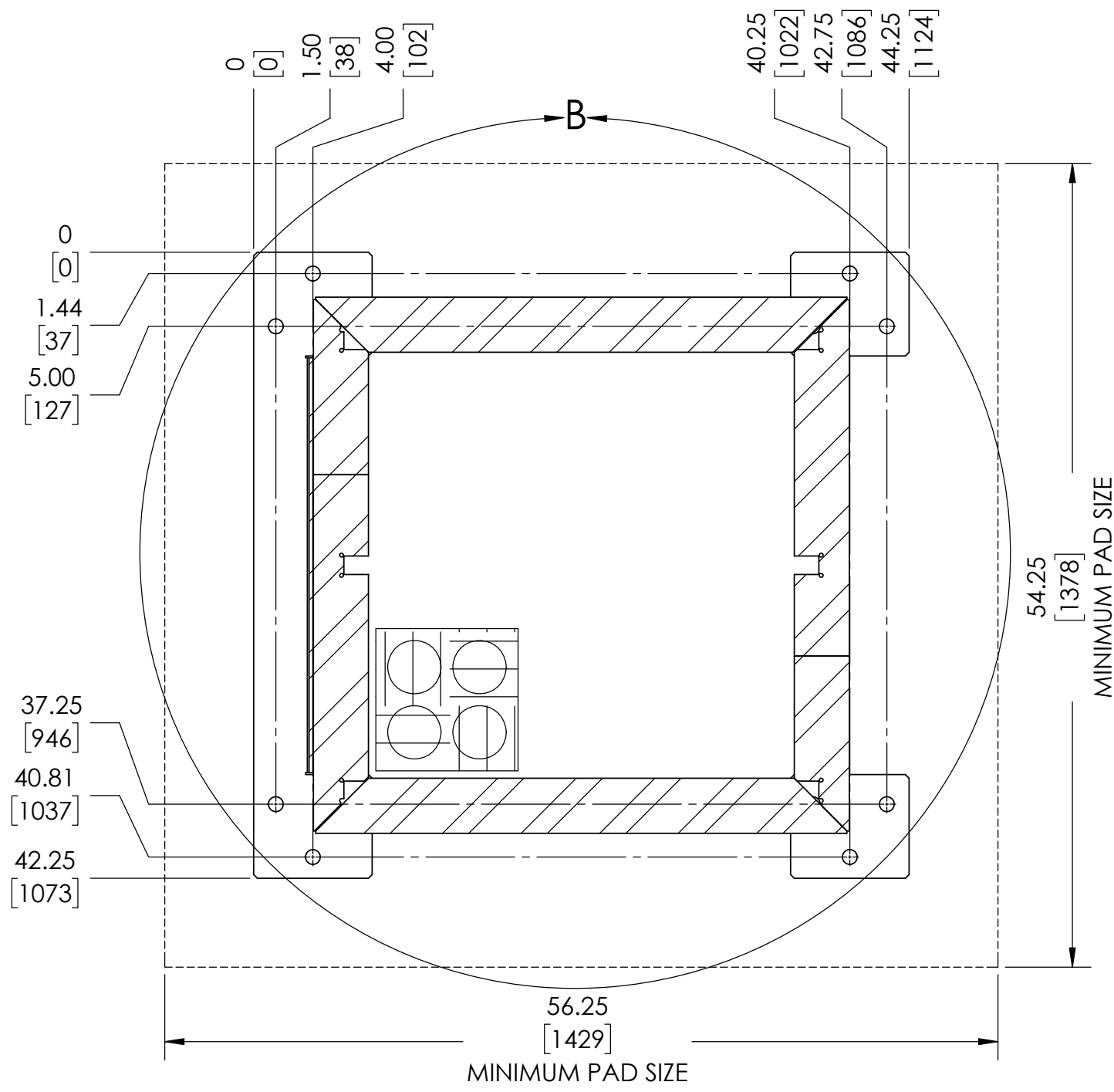

STUB-UP LOCATIONS
DETAIL B
SCALE 1 : 8

NOTES:

1. MOUNTING DIMENSIONS SHOWN ON DRAWING ARE FINAL. WE RECOMMEND PLACING CONSOLE THEN DRILLING FOR MOUNTING ANCHORS.
2. ANCHOR BOLTS ARE TO BE HILTI M12 HDA-TR STAINLESS STEEL UNDERCUT (OR EQUIVALENT). HOLE DEPTH TO BE MINIMUM OF 5.3" [135mm], PAD DEPTH TO BE MINIMUM OF 8.0" [203mm]
3. CONCRETE PAD TO EXTEND A MINIMUM OF 6" [153mm] FROM EDGE OF CABINET ON ALL SIDES. SEE MOUNTING DIMENSIONS BELOW. THE WEIGHT OF THE CONSOLE WITH BATTERIES (SPECIFIED IN PURCHASE ORDER) IS 1282lb [582kg]
4. CONCRETE PAD TO BE 4000 psi OR GREATER.
5. ELECTRICAL CONDUIT MAY ENTER FROM UNDERNEATH CABINET, BUT ONLY THROUGH STUB-UP LOCATIONS SHOWN IN DETAIL B.
6. CONDUIT ENTRY PROVIDED THROUGH SIDE PANEL 10.5in BY 14in GLAND PLATE AVAILABLE FOR KNOCKOUT. KNOCKOUTS MAY NOT BE VISIBLE, USE DIMENSIONS TO VERIFY BREAKAWAY POINTS.

C:\Hindle Vault\Custom Drawings\CONSOLES 2.12.11 SEC

| | | | |
|--|--|---|--|
| UNLESS OTHERWISE SPECIFIED ALL DIMENSIONS FOLLOW THE AND SYSTEMS (INCHES FRACTIONS & DECIMALS) TOLERANCES ARE FRAC: 1/16" DEC: .015" UNLESS NOTED OTHERWISE | | HINDLEPOWER | |
| PROPERTY AND CONFIDENTIAL NOTICE ANY REPRODUCTION, PARTIAL OR AS A WHOLE OF THIS DOCUMENT WITHOUT THE WRITTEN PERMISSION OF HINDLEPOWER IS STRICTLY PROHIBITED | | EPIC SERIES 2.0 CONSOLE FOUNDATION DRAWINGS SALES ORDER No. N/A | |
| TITLE | | SCALE: DWG No. JE5276-01 | |
| REV. SHEET | | A 3 OF 3 | |

| REV. | DATE | DESCRIPTION | DWN BY | CHK BY | APP BY |
|-----------|-----------|-------------------|--------|--------|--------|
| A | 6/10/2020 | STANDARD DRAWINGS | KJB | ND | ND |
| REVISIONS | | | | | |

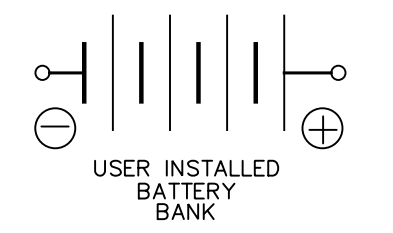
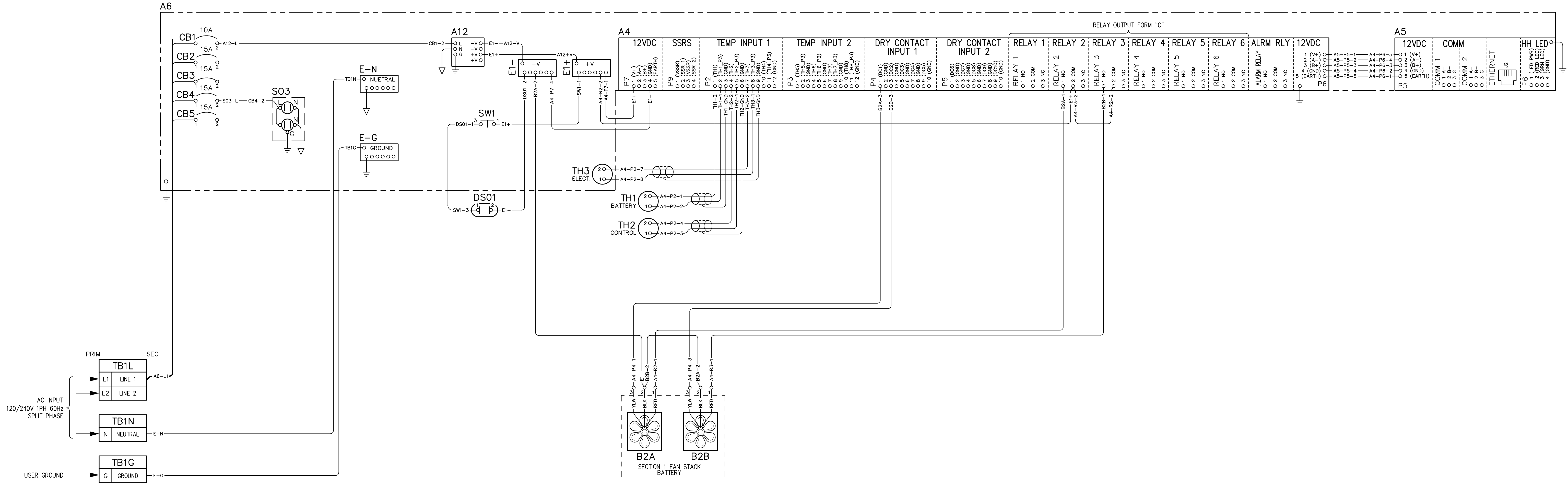

EPIC SERIES COMPONENTS

| SYMBOL | DESCRIPTION |
|--------|-------------------------------------|
| A4 | HINDLE HEALTH CONTROLLER |
| A5 | HINDLE HEALTH DISPLAY |
| A6 | EPIC CONTROLLER |
| A12 | 12VDC POWER SUPPLY |
| B#X | VENT FANS |
| CB1 | CIRCUIT BREAKER FOR A12 P/S |
| CB2 | CIRCUIT BREAKER FOR HEATING SYSTEM |
| CB3 | CIRCUIT BREAKER FOR AIR CONDITIONER |
| CB4 | CIRCUIT BREAKER FOR GFI OUTLET |
| DS01 | CONSOLE LED LIGHTS |
| E1X | 12VDC CONNECTION POINTS |
| E-G | GROUND CONNECTION POINTS |
| E-N | NEUTRAL CONNECTION POINTS |
| E1+ | 15A GFI OUTLET |
| SW1 | CONSOLE LED LIGHT SWITCH(ES) |
| TB1X | AC INPUT TERMINAL BLOCK |
| TH1 | BATTERY THERMAL SENSOR |
| TH2 | CONTROL THERMAL SENSOR |
| TH3 | ELECTRONIC SECTION THERMAL SENSOR |

LEGEND FOR EPIC LINE

| SYMBOL | DESCRIPTION |
|--------|---|
| ○ | DEVICE TERMINAL |
| ⊙ | TERMINAL BLOCK POINT IN TRANSFORMER |
| ⊖ | TERMINAL BLOCK POINT FOR SCADA |
| ⊕ | TERMINAL BLOCK POINT FOR COMMUNICATIONS |
| ⊖ | TERMINAL BLOCK POINT IN POWER CIRCUIT BREAKER |
| ▲ | TERMINAL IN A.C. OR D.C. PANELBOARD |
| — | SHIPPED WITH WIRING INSTALLED |
| - - - | WIRING TO BE INSTALLED |

| I/O TERMINAL | DESCRIPTION - TYPE | CONNECTION |
|---------------|---|-------------|
| TB1L,N,G PRIM | LINE 1, LINE 2 AC INPUT / USER NTRL, GND TERMINALS - CU-ALUMINUM COMP LUG | 2/0-#14 AWG |
| TB1L,N,G SEC | LINE 1, LINE 2 AC INPUT / USER NTRL, GND TERMINALS - CU-ALUMINUM COMP LUG | #4-#14 AWG |

| REV. | DATE | DESCRIPTION | DRN BY | CHK BY | APP BY |
|------|-----------|-------------------|--------|--------|--------|
| A | 7/15/2020 | STANDARD DRAWINGS | KJB | ND | ND |

UNLESS OTHERWISE SPECIFIED ALL DIMENSIONS SHALL FOLLOW THE ANSI SYSTEM (INCHES/POUNDS & SECONDS) TOLERANCES ARE: FRACTIONAL DEC. ±.015, ANG ±.02°

PROPERTY AND CONFIDENTIAL NOTICE ANY REPRODUCTION, PARTIAL OR AS A WHOLE OF THIS DOCUMENT WITHOUT THE WRITTEN PERMISSION OF HINDLE POWER, INC IS STRICTLY PROHIBITED.

1075 Saint John Street
Easton, PA 18042-6661
PH 610-330-9000 FAX 610-330-8510
www.hindlepowerinc.com

TITLE: EPIC SERIES 2.0 CONSOLE CONNECTION DIAGRAM: 0 ELEC. SECTIONS 1 BATT SECTION SALES ORDER NO. N/A

SCALE: DWG No. **JE5272-01** SHEET 1 OF 1

[JE5272-00.DWG]