

**DUAL CHARGER OPERATION  
 WITH BATTERY DISCHARGE ALARM OR AMMETER**

**BACKGROUND**

Battery charger options that indicate if a connected battery is charging or discharging are specifically designed for one battery charger, one battery bank, and one load connection. Some installations require a battery and dc load linked to two independent chargers, connected in parallel. These arrangements can cause an incorrect battery discharge alarm or incorrect battery discharge indication.

When an SCR/SCRF or AT10.1/AT30 Series battery charger has an optional Battery Discharge Alarm or Battery Discharge Ammeter installed, the I/O panel is supplied with a third dc output terminal, labeled BATT (-). The existing dc output terminals are labeled LOAD (-), and BATT & LOAD (+). Refer to the table below:

Option Description	Product Line	Option / Drawing No.	DC Output Terminals	Supplied Components
Battery Discharge Alarm	SCR/SCRF	EJ0120	TB2- L(-),L(+),B/L(+)	A5, DS10, SH3, TB3
Battery Discharge Ammeter	SCR/SCRF	EJ0138	TB2- L(-),L(+),B/L(+)	M7, SH2
Battery Discharge Alarm	AT10.1/AT30	EJ5136	TB1- L(-),L(+),B/L(+)	A18, R30, TB9
Battery Discharge Ammeter	AT10.1/AT30	EJ5163	TB1- L(-),L(+),B/L(+)	M7, R30

**CONNECTING CHARGERS IN PARALLEL**

To prevent problems with false alarms, connect the two chargers to the load and battery as shown in **Figure 1** below.

**Figure 1**

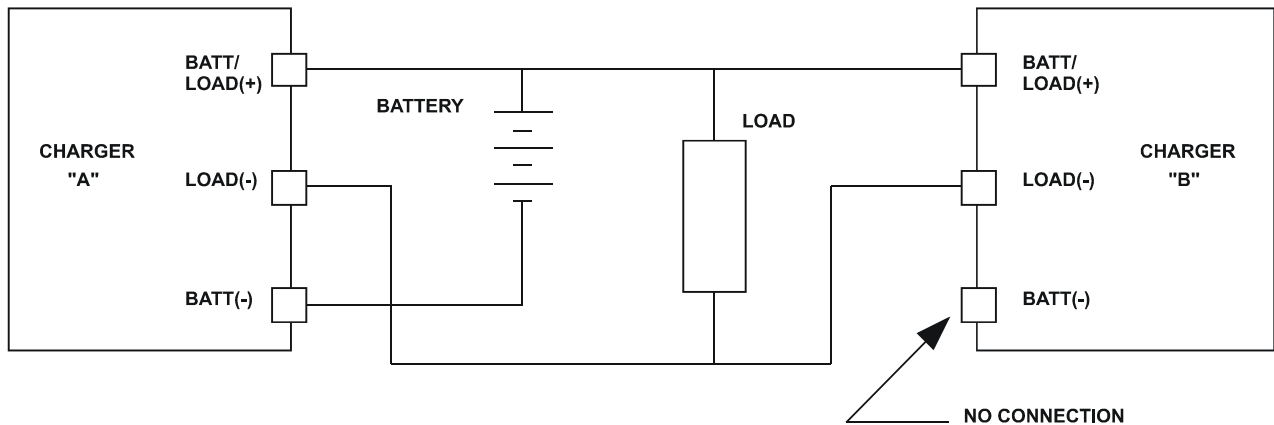

With this arrangement the Battery Discharge Alarm or Ammeter in Charger "A" operates normally. The Battery Discharge Alarm or Ammeter in Charger "B" is prevented from working, so that it cannot give false alarms.

If the load is very light, be sure that Charger "A" supplies the load current. You can do this by setting the float voltage on Charger "A" about 0.1 V higher than the float voltage on Charger "B".

**TO SERVICE OR MAINTAIN A CHARGER**

If you need to take Charger "A" out of service for any reason, move the battery negative terminal connection from Charger "A" to Charger "B", connecting it to the BATT(-) terminal. Now the Battery Discharge option in Charger "B" will operate normally.

**USING PARALLEL FORCED LOAD SHARING OPTIONS****SCR/SCRF Series (EJ0133-00)**

Make the load share signal connections to TB4 in both chargers, according to drawing EJ0133 in your Operating and Service Instructions manual. Wire the battery and load to the charger dc output terminals (TB2) as described and shown in **Figure 1**.

During normal operation, the chargers will supply equal charging current. During battery discharge, the Battery Discharge option in Charger "A" will operate normally.

**AT10.1/AT30 Series (EJ5126-XX)**

Make the load share signal connections to J35 in both chargers, according to the option drawing JE5154-00. Wire the battery and load to the charger dc output terminals (TB1) as described and shown in Figure 1.

During normal operation, the chargers will supply equal charging current. During battery discharge, the Battery Discharge option in Charger "A" will operate normally.