

# DC POWER ISOLATOR

ISOLATING STEERING DIODE ASSEMBLY  
FOR REDUNDANT DC POWER SYSTEMS

## Typical Schematic/Wiring Diagram For 130Vdc Redundant System

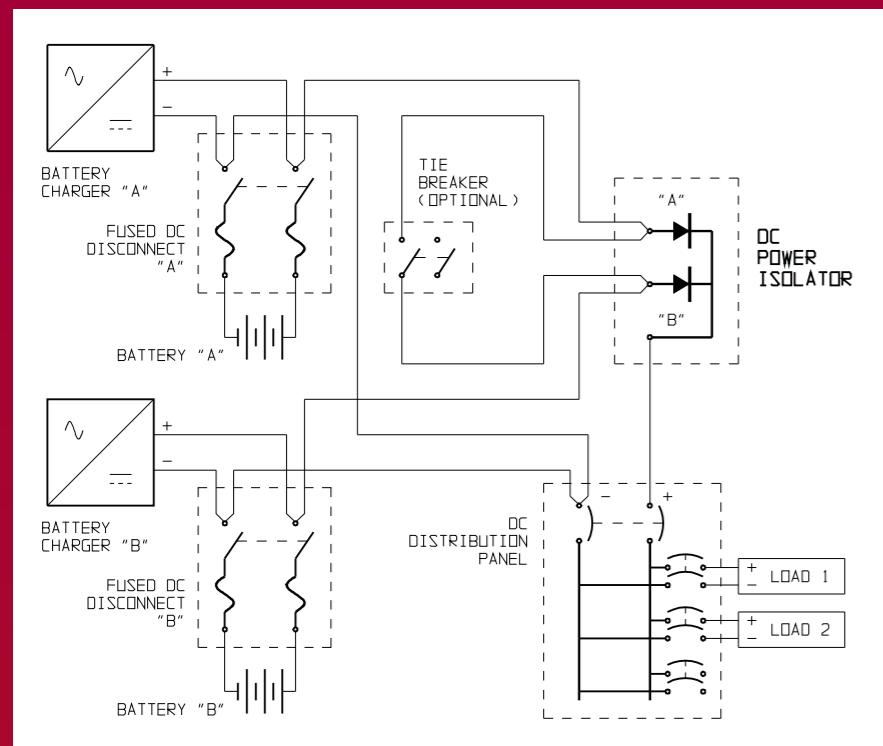

### Fused DC Disconnect

- Allows battery to be removed from system for easy maintenance.

### DC Power Isolator

- Isolation ensures system integrity in the event of failure on either bus.
- Uniform shared discharge of both battery banks.
- Seamless transfer of supply from either bus.

### Tie Breaker

- Allows Battery Charger "A" to service Battery "B", or vice versa.



## Looking for 'True System Redundancy'?

Using a steering diode assembly (DC Power Isolator) is an extremely effective and low cost method of providing true dc battery system protection and redundancy. The DC Power Isolator works automatically with no mechanical switching and requires no operator intervention.

### Other Products Available from HindlePower:

AT10.1 Microprocessor Battery Charger	JF5006-00	SCR/SCRF Series Utility Battery Charger	JF5010-00
AT30 Microprocessor Battery Charger	JF5018-00	UMC Universal Maintenance Charger	JF5008-00
AT Series Options & Accessories	JF5020-00	Single Cell Charger	JF5007-00
AT Series Communications Module	JF5014-00	EPIC Console	JF5043-00
AT-DC Series Distribution Panel	JF5032-00	Customized DC Power Trailer	JF5041-00

This product distributed by:

**HINDLEPOWER**  
Quality & Integrity - Our Passion

**HINDLEPOWER**  
Quality & Integrity - Our Passion

## What is the "DC Power Isolator™"?

The DC Power Isolator™ system is a power diode arrangement that uses multiple parallel battery circuits while ensuring that no single battery will ever be a burden on the system. The DC Power Isolator™ is a passive device that requires no user intervention and helps to ensure battery viability regardless of any battery's health. The DC Power Isolator™ does not rely on mechanical or operator intervention.

## How does it solve my system's lack of 'true redundancy'?

NERC – Draft 840, Protection System Reliability, October 2004 discusses the use of redundancy as a method to ensure system reliability. When two or more batteries are paralleled, electrical isolation is required so that system redundancy is not compromised.

An isolation method that uses a mechanical switch device for complete isolation means either the automatic switch or the operator must decide which battery to use and transfer the switch accordingly. In both cases a decision must be made by either a person or a device to determine which battery circuit is viable. In contrast, the DC Power Isolator™ does not require the operator or switch to determine the viability of a battery; therefore neither device nor human error will be detrimental to proper operation.

## How does the "DC Power Isolator™" function?

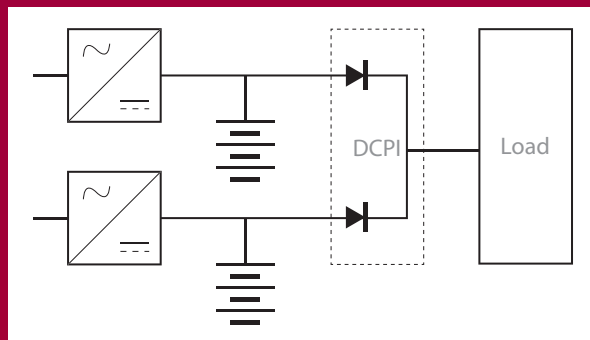

This schematic illustrates how the DC Power Isolator™ operates. Listed below are the applications where the DC Power Isolator™ is best suited ...

- Utility Switchgear
- Engine Starting
- Communications
- Lube Oil Pumps
- Turbine Controls

### STANDARD FEATURES:

- Solid state design using diodes mounted on aluminum heat sinks for heat dissipation.
- Complete diode assembly housed in rugged NEMA 1 metal enclosure with a powder-coat baked-on epoxy finish in ANSI 61 Gray.
- Convection cooled
- Automatic operation with no maintenance required.
- 5-Year Warranty

### OPTIONAL FEATURES:

- DC Load Voltmeter
- DC Load Ammeter
- High/ Low DC Voltage Alarm with Indicator
- End of Discharge Alarm with Indicator
- End of Discharge Alarm with Indicator & Disconnect
- DC Load Disconnect Circuit Breaker

## Standard DC Power Isolator™ Models

HindlePower P/N	Voltage (max)	Current (continous @50C)	Current (1 sec)	Current (30sec 50C)	Battery/ Charger Quantity	CAB N1 Style	I/O Connector
EJ5144-00	300	50	1000	450	2	1A	1/4" stud
EJ5144-01	300	100	1000	450	2	1A	1/4" stud
EJ5144-02	300	200	1000	450	2	1B	3/8" stud
EJ5144-03	300	500	3500	2000	2	1B	Lug #2-600MCM
EJ5144-04	600	50	1000	450	2	1A	1/4" stud
EJ5144-05	600	100	1000	450	2	1A	1/4" stud
EJ5144-06	600	200	1000	450	2	1B	3/8" stud
EJ5144-07	600	500	3500	2000	2	1B	Lug #2-600MCM
EJ5144-12	600	750	8700	6800	2	2	Lug 300-800MCM
EJ5144-09	300	100	1000	450	3	1B	1/4" stud
EJ5144-10	300	200	1000	450	3	1B	3/8" stud
EJ5144-11	300	500	3500	2000	3	2	Lug #2-600MCM

### STYLE 1A - NEMA 1 enclosure

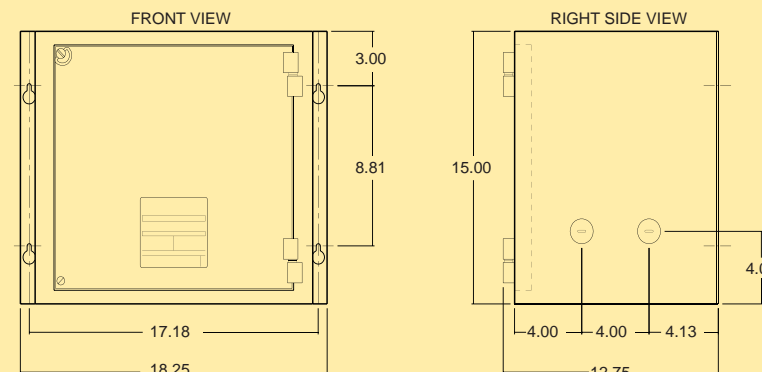

### STYLE 2 - NEMA 1 enclosure

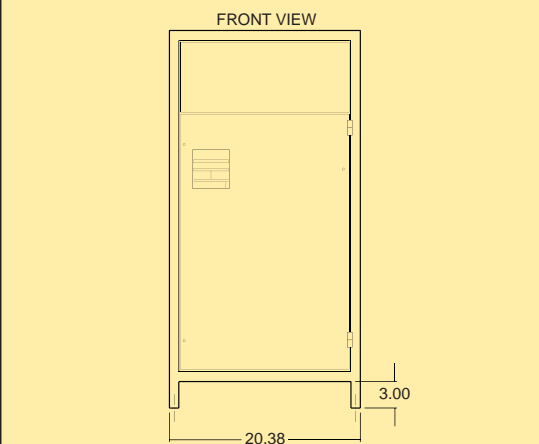

### STYLE 1B - NEMA 1 enclosure

